

The Transport Layer

Chapter 6

Transport Service

- Upper Layer Services
- Transport Service Primitives
- Berkeley Sockets
- Example of Socket Programming:
Internet File Server

Services Provided to the Upper Layers

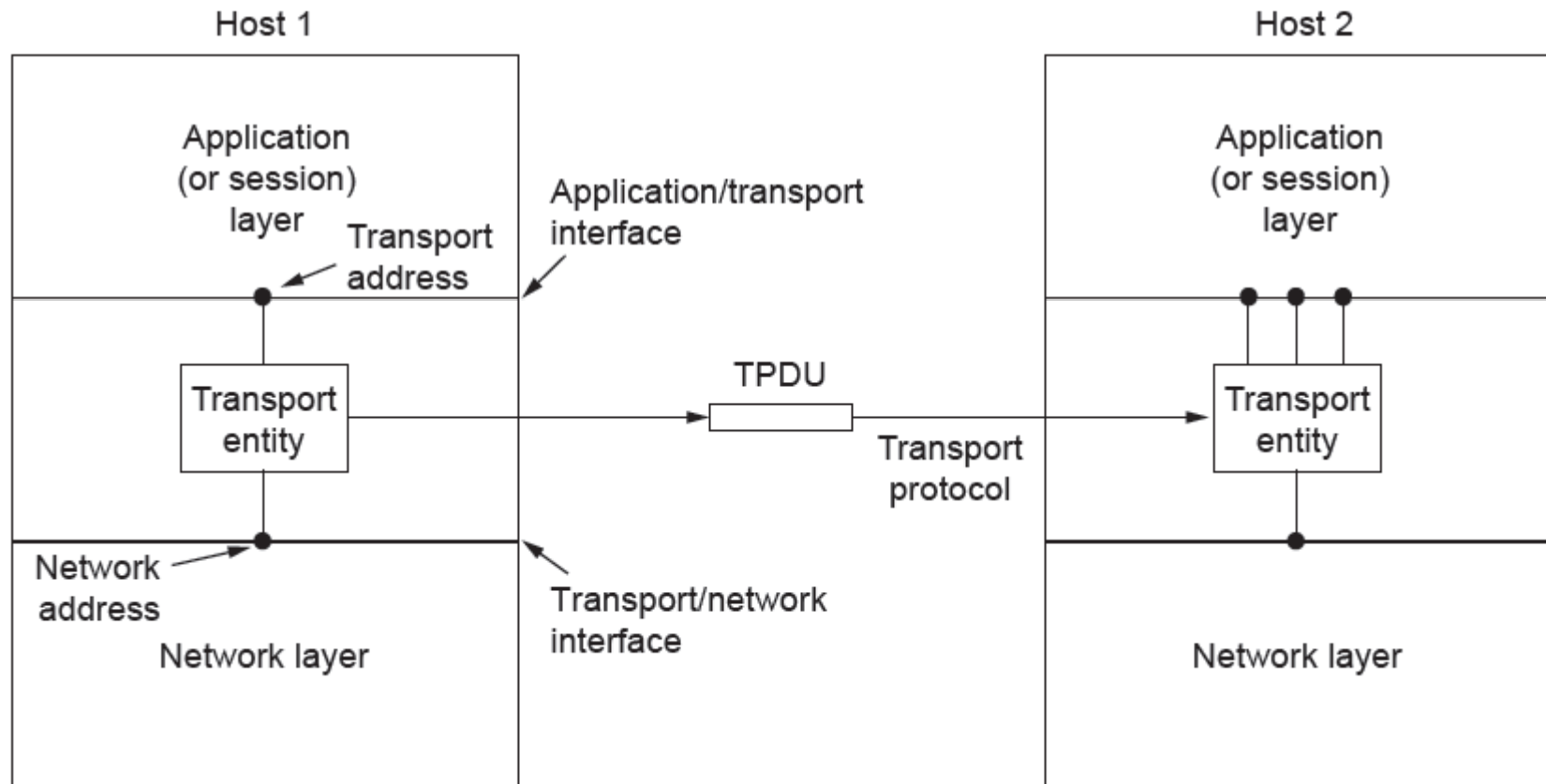

The network, transport, and application layers

Transport Service Primitives (1)

Primitive	Packet sent	Meaning
LISTEN	(none)	Block until some process tries to connect
CONNECT	CONNECTION REQ.	Actively attempt to establish a connection
SEND	DATA	Send information
RECEIVE	(none)	Block until a DATA packet arrives
DISCONNECT	DISCONNECTION REQ.	This side wants to release the connection

The primitives for a simple transport service

Transport Service Primitives (2)

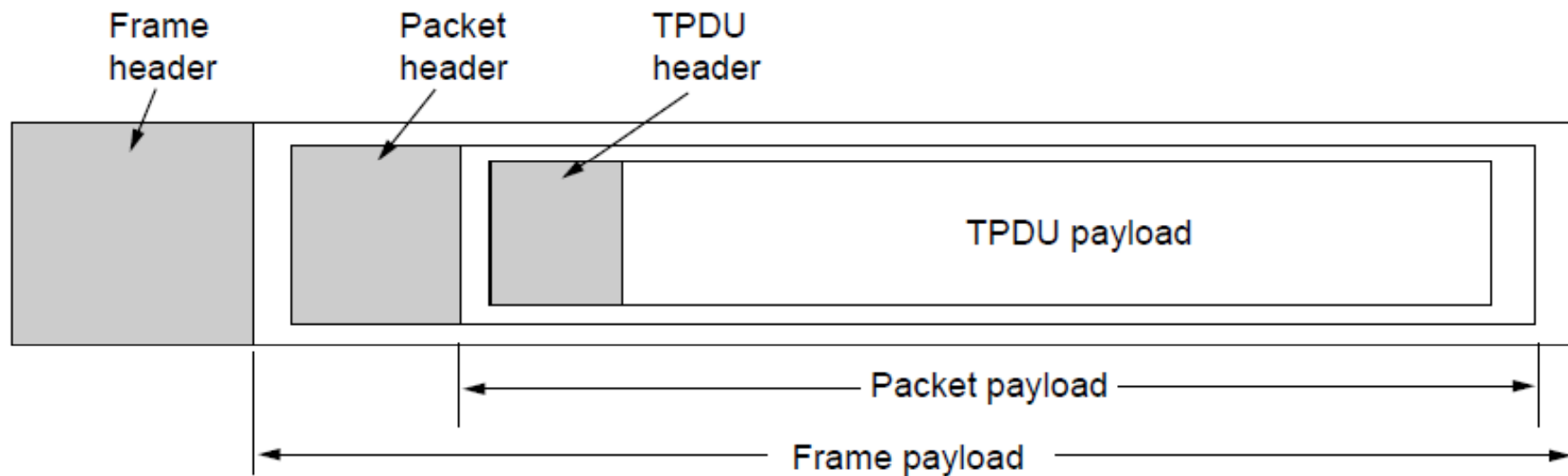

Nesting of TPDU, packets, and frames.

Berkeley Sockets (1)

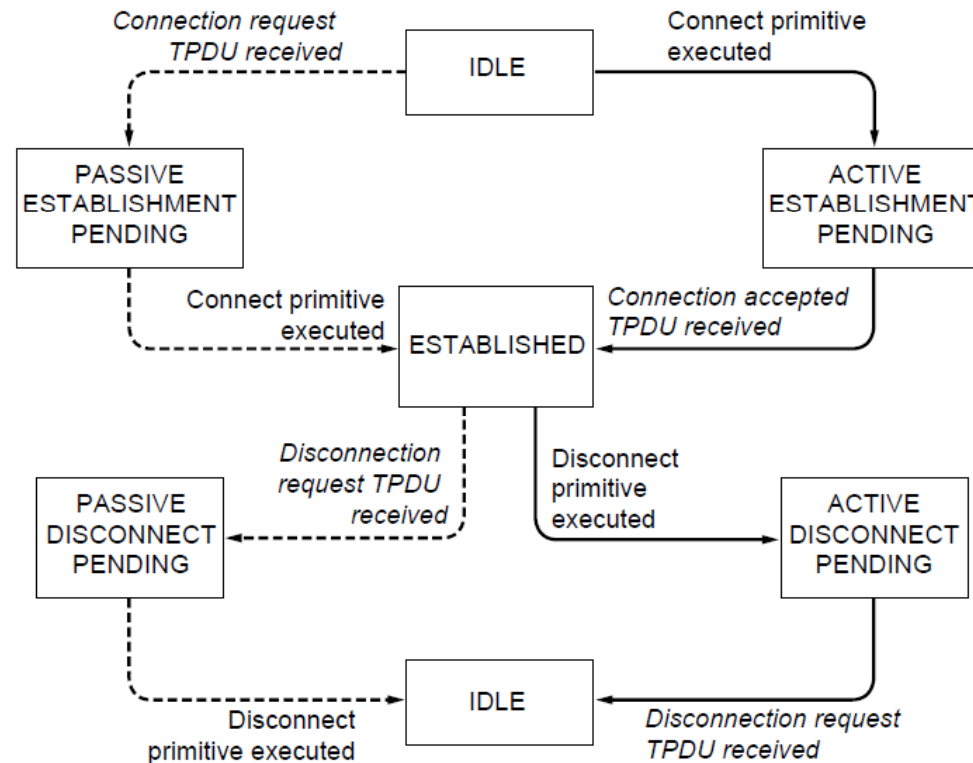

A state diagram for a simple connection management scheme. Transitions labeled in italics are caused by packet arrivals. The solid lines show the client's state sequence. The dashed lines show the server's state sequence.

Berkeley Sockets (2)

Primitive	Meaning
SOCKET	Create a new communication end point
BIND	Associate a local address with a socket
LISTEN	Announce willingness to accept connections; give queue size
ACCEPT	Passively establish an incoming connection
CONNECT	Actively attempt to establish a connection
SEND	Send some data over the connection
RECEIVE	Receive some data from the connection
CLOSE	Release the connection

The socket primitives for TCP

Example of Socket Programming: An Internet File Server (1)

```
/* This page contains a client program that can request a file from the server program
 * on the next page. The server responds by sending the whole file.
 */

#include <sys/types.h>
#include <sys/socket.h>
#include <netinet/in.h>
#include <netdb.h>

#define SERVER_PORT 12345          /* arbitrary, but client & server must agree */
#define BUF_SIZE 4096            /* block transfer size */

int main(int argc, char **argv)
{
    int c, s, bytes;
    char buf[BUF_SIZE];           /* buffer for incoming file */
    struct hostent *h;            /* info about server */
    struct sockaddr_in channel;   /* holds IP address */

    . . .
```

Client code using sockets

Example of Socket Programming: An Internet File Server (2)

...

```
if (argc != 3) fatal("Usage: client server-name file-name");
h = gethostbyname(argv[1]);           /* look up host's IP address */
if (!h) fatal("gethostbyname failed");

s = socket(PF_INET, SOCK_STREAM, IPPROTO_TCP);
if (s < 0) fatal("socket");
memset(&channel, 0, sizeof(channel));
channel.sin_family= AF_INET;
memcpy(&channel.sin_addr.s_addr, h->h_addr, h->h_length);
channel.sin_port= htons(SERVER_PORT);

c = connect(s, (struct sockaddr *) &channel, sizeof(channel));
if (c < 0) fatal("connect failed");
```

...

Client code using sockets

Example of Socket Programming: An Internet File Server (3)

...

```
c = connect(s, (struct sockaddr *) &channel, sizeof(channel));
if (c < 0) fatal("connect failed");

/* Connection is now established. Send file name including 0 byte at end. */
write(s, argv[2], strlen(argv[2])+1);

/* Go get the file and write it to standard output. */
while (1) {
    bytes = read(s, buf, BUF_SIZE);           /* read from socket */
    if (bytes <= 0) exit(0);                  /* check for end of file */
    write(1, buf, bytes);                     /* write to standard output */
}
}
fatal(char *string)
{
    printf("%s\n", string);
    exit(1);
}
```

Client code using sockets

Example of Socket Programming: An Internet File Server (4)

```
#include <sys/types.h>                /* This is the server code */
#include <sys/fcntl.h>
#include <sys/socket.h>
#include <netinet/in.h>
#include <netdb.h>

#define SERVER_PORT 12345              /* arbitrary, but client & server must agree */
#define BUF_SIZE 4096                 /* block transfer size */
#define QUEUE_SIZE 10

int main(int argc, char *argv[])
{
    int s, b, l, fd, sa, bytes, on = 1;
    char buf[BUF_SIZE];                /* buffer for outgoing file */
    struct sockaddr_in channel;        /* holds IP address */

    . . .
```

Server code

Example of Socket Programming: An Internet File Server (5)

...

```
/* Build address structure to bind to socket. */
memset(&channel, 0, sizeof(channel));    /* zero channel */
channel.sin_family = AF_INET;
channel.sin_addr.s_addr = htonl(INADDR_ANY);
channel.sin_port = htons(SERVER_PORT);

/* Passive open. Wait for connection. */
s = socket(AF_INET, SOCK_STREAM, IPPROTO_TCP); /* create socket */
if (s < 0) fatal("socket failed");
setsockopt(s, SOL_SOCKET, SO_REUSEADDR, (char *) &on, sizeof(on));

b = bind(s, (struct sockaddr *) &channel, sizeof(channel));
if (b < 0) fatal("bind failed");

l = listen(s, QUEUE_SIZE);                /* specify queue size */
if (l < 0) fatal("listen failed");
```

...

Server code

Example of Socket Programming: An Internet File Server (6)

...

```
/* Socket is now set up and bound. Wait for connection and process it. */
while (1) {
    sa = accept(s, 0, 0);                /* block for connection request */
    if (sa < 0) fatal("accept failed");

    read(sa, buf, BUF_SIZE);           /* read file name from socket */

    /* Get and return the file. */
    fd = open(buf, O_RDONLY);          /* open the file to be sent back */
    if (fd < 0) fatal("open failed");

    while (1) {
        bytes = read(fd, buf, BUF_SIZE); /* read from file */
        if (bytes <= 0) break;          /* check for end of file */
        write(sa, buf, bytes);         /* write bytes to socket */
    }
    close(fd);                          /* close file */
    close(sa);                          /* close connection */
}
}
```

Server code

Elements of Transport Protocols (1)

- Addressing
- Connection establishment
- Connection release
- Error control and flow control
- Multiplexing
- Crash recovery

Elements of Transport Protocols (2)

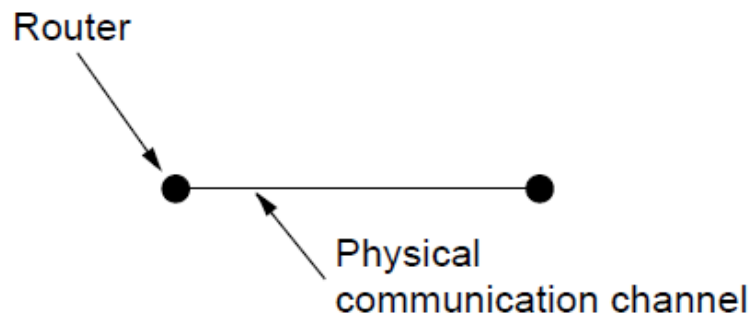

(a)

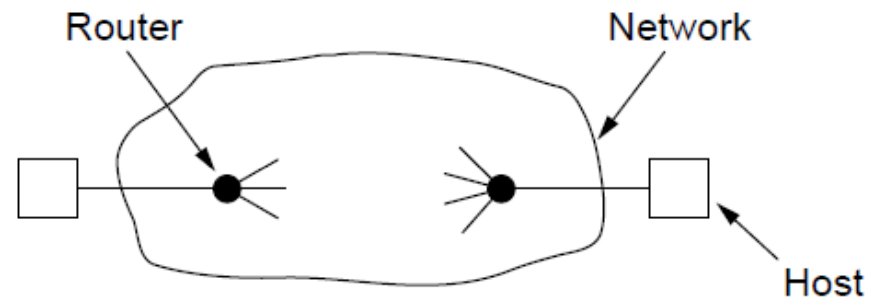

(b)

- (a) Environment of the data link layer.
- (b) Environment of the transport layer.

Addressing (1)

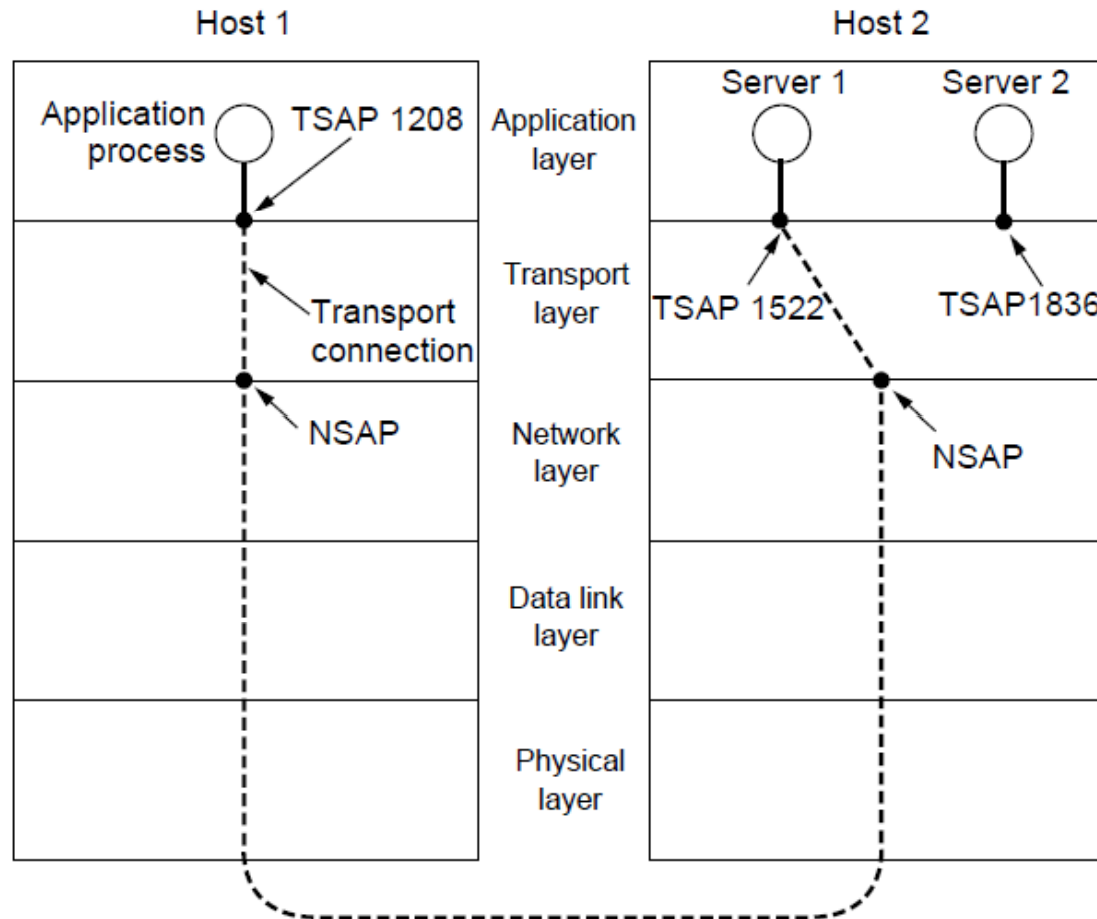

TSAPs, NSAPs, and transport connections

Addressing (2)

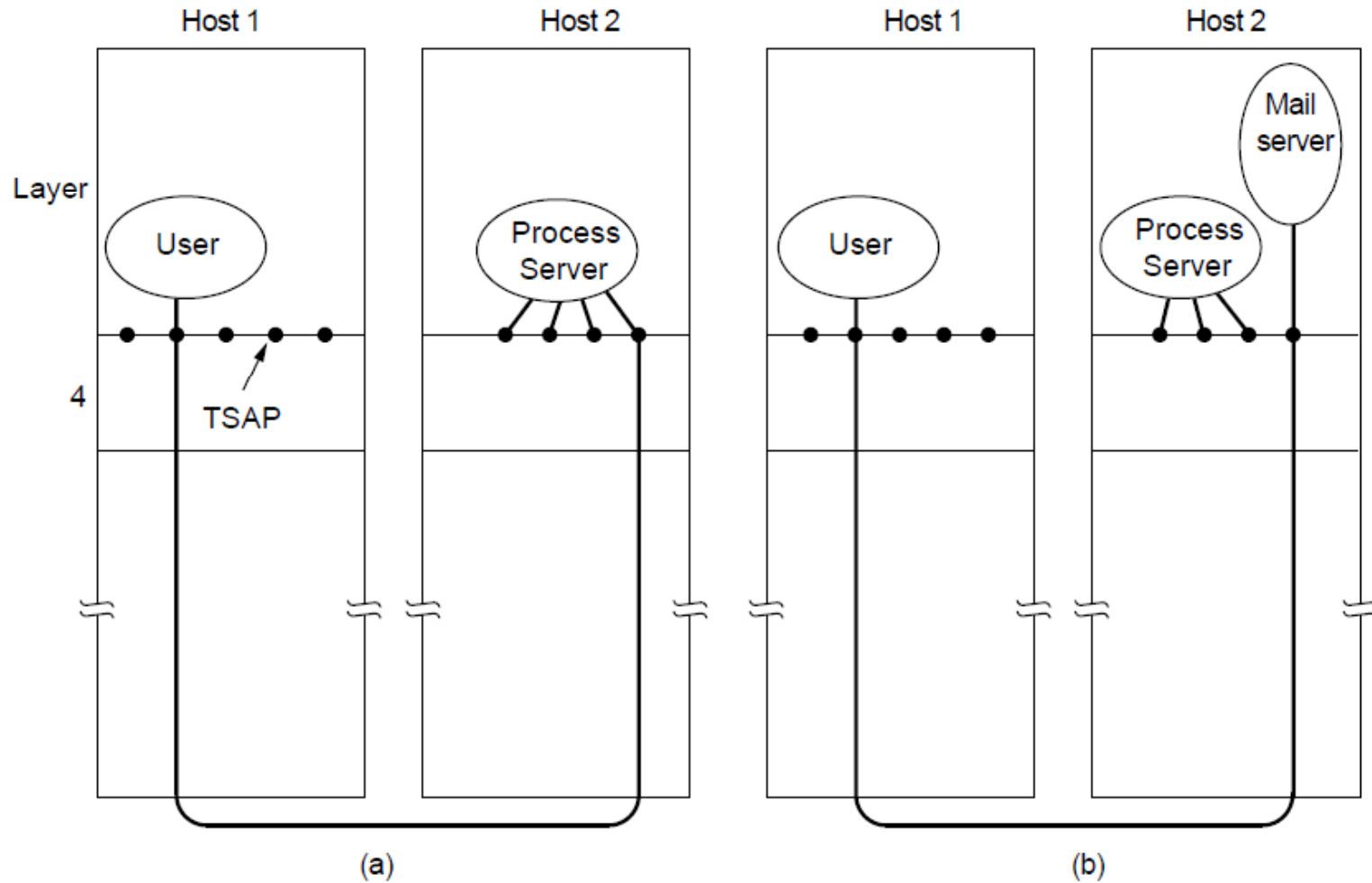

How a user process in host 1 establishes a connection with a mail server in host 2 via a process server.

Connection Establishment (1)

Techniques for restricting packet lifetime

- Restricted network design.
- Putting a hop counter in each packet.
- Timestamping each packet.

Connection Establishment (2)

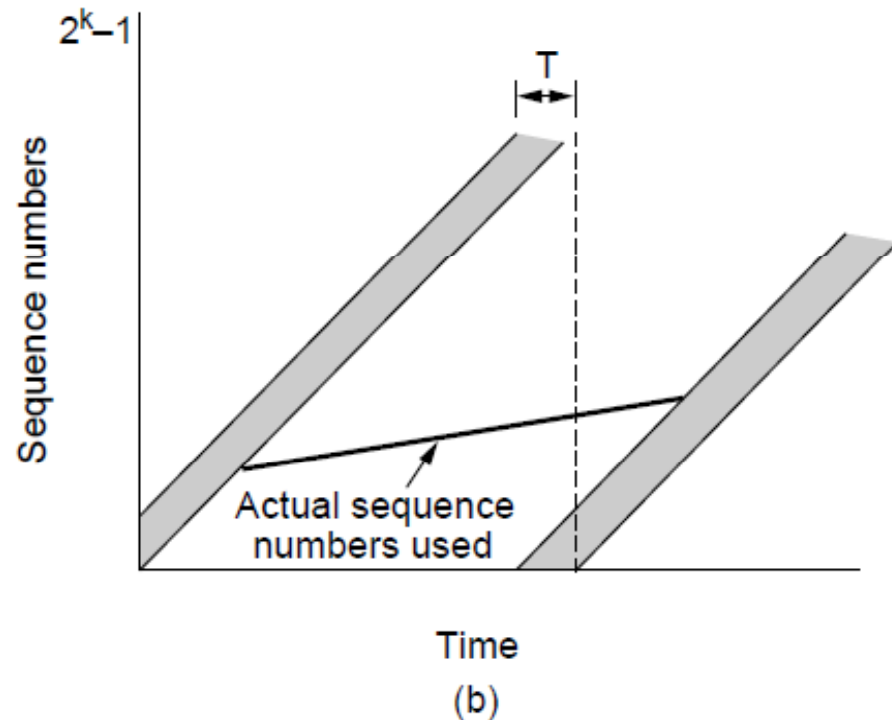
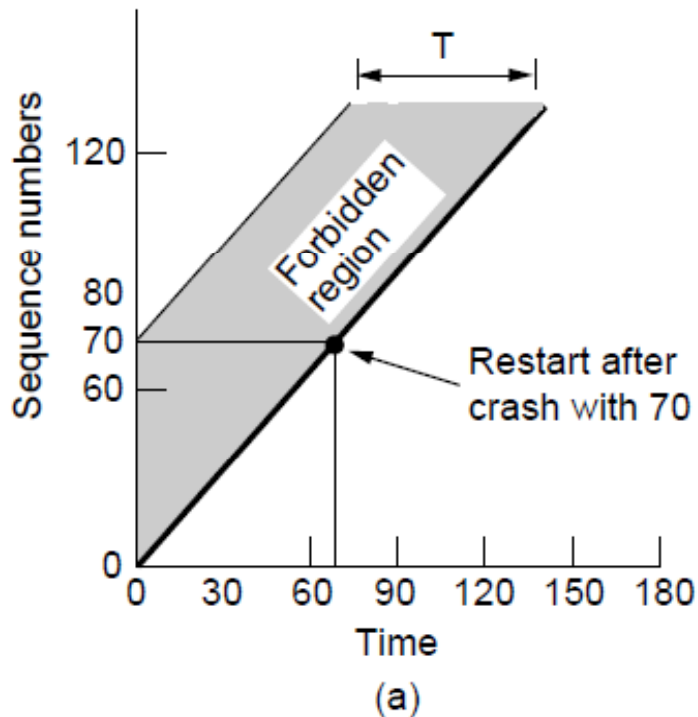

- (a) TPDU's may not enter the forbidden region.
- (b) The resynchronization problem.

Connection Establishment (3)

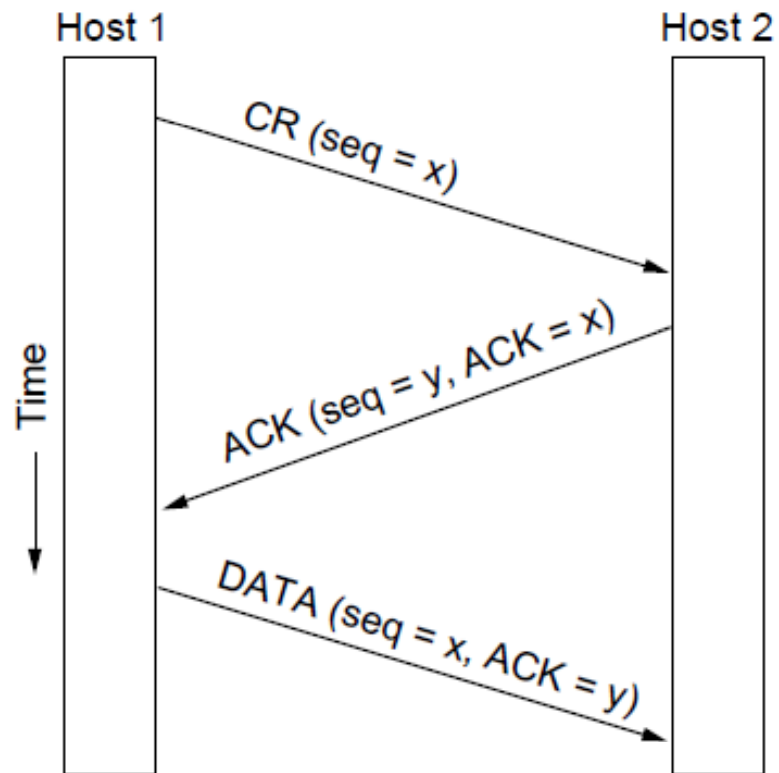

Three protocol scenarios for establishing a connection using a three-way handshake. CR denotes CONNECTION REQUEST. Normal operation.

Connection Establishment (4)

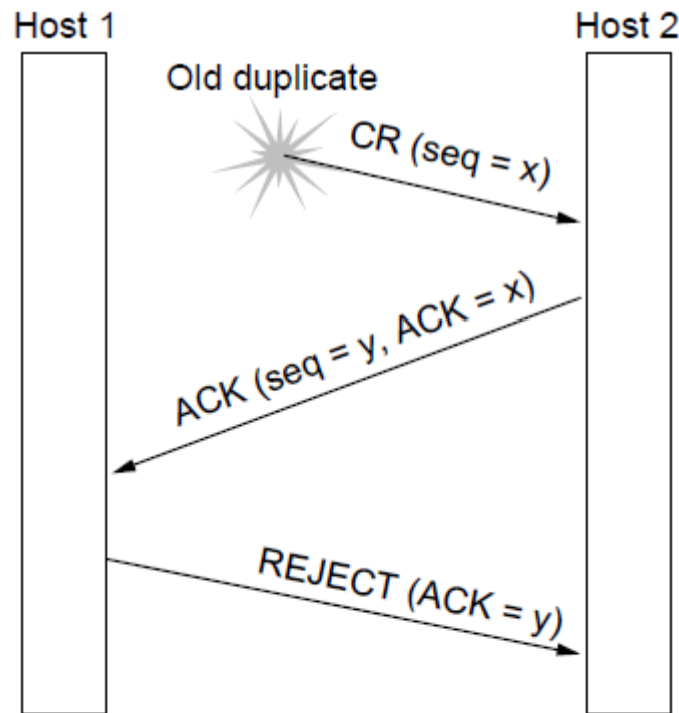

Three protocol scenarios for establishing a connection using a three-way handshake. CR denotes CONNECTION REQUEST. Old duplicate CONNECTION REQUEST appearing out of nowhere.

Connection Establishment (5)

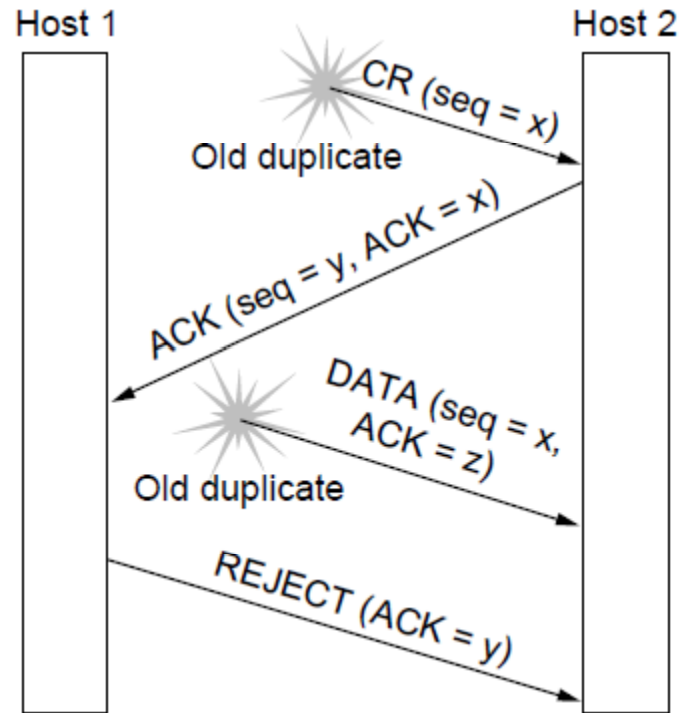

Three protocol scenarios for establishing a connection using a three-way handshake. CR denotes CONNECTION REQUEST. Duplicate CONNECTION REQUEST and duplicate ACK

Connection Release (1)

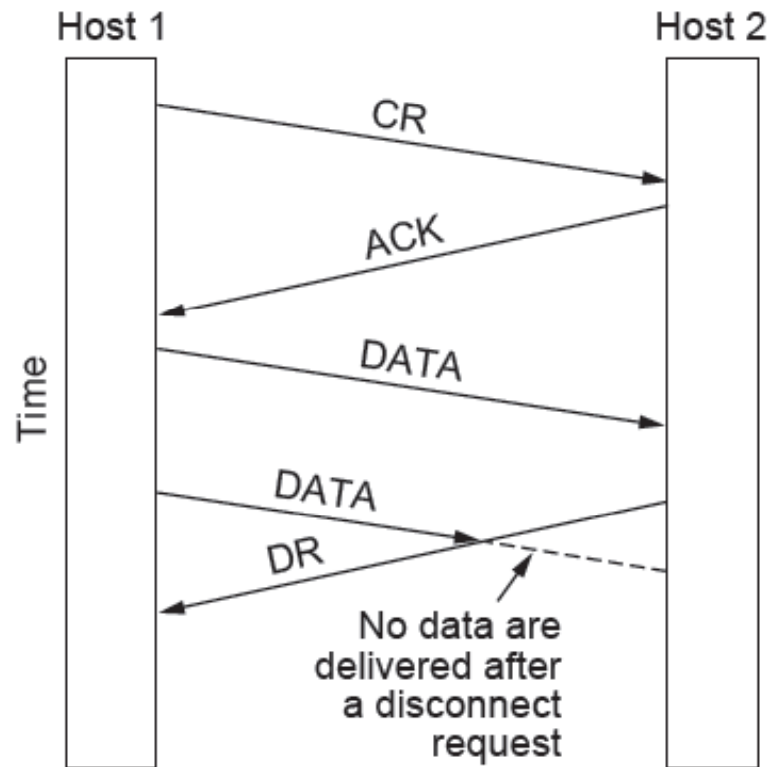

Abrupt disconnection with loss of data

Connection Release (2)

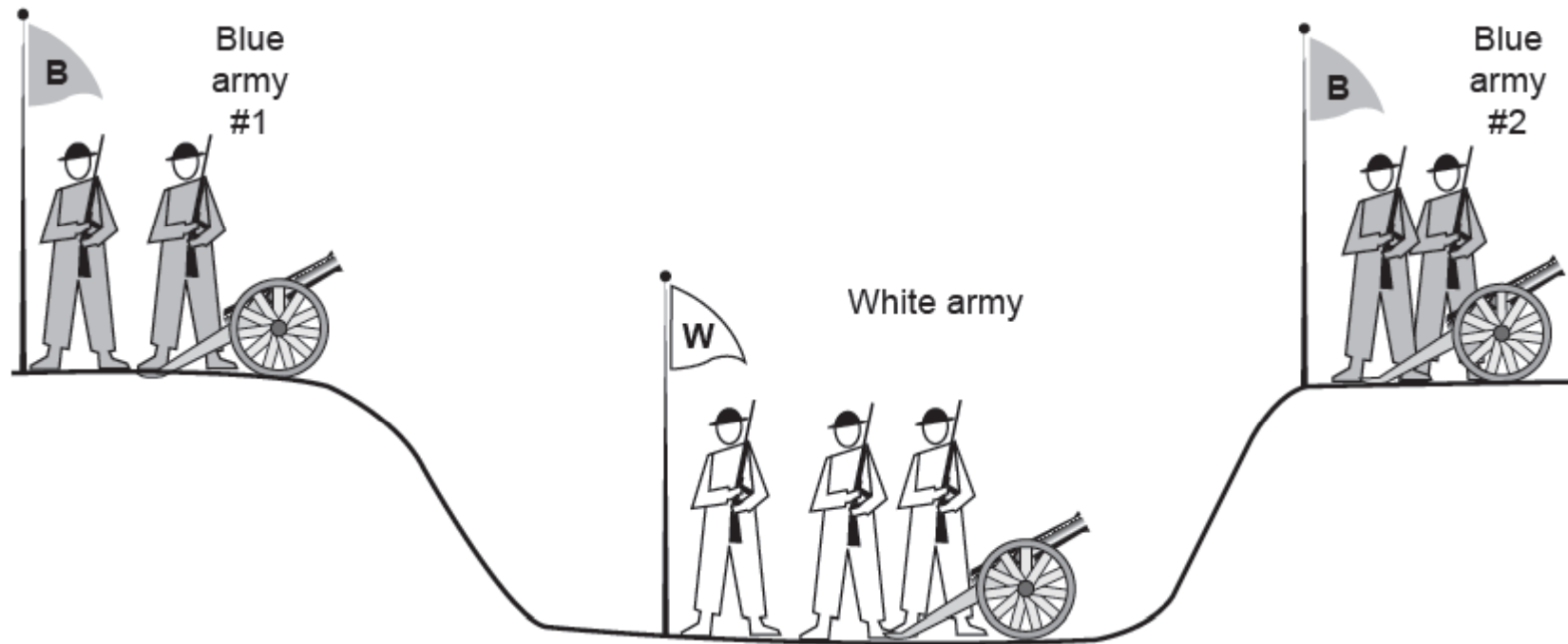

The two-army problem

Connection Release (3)

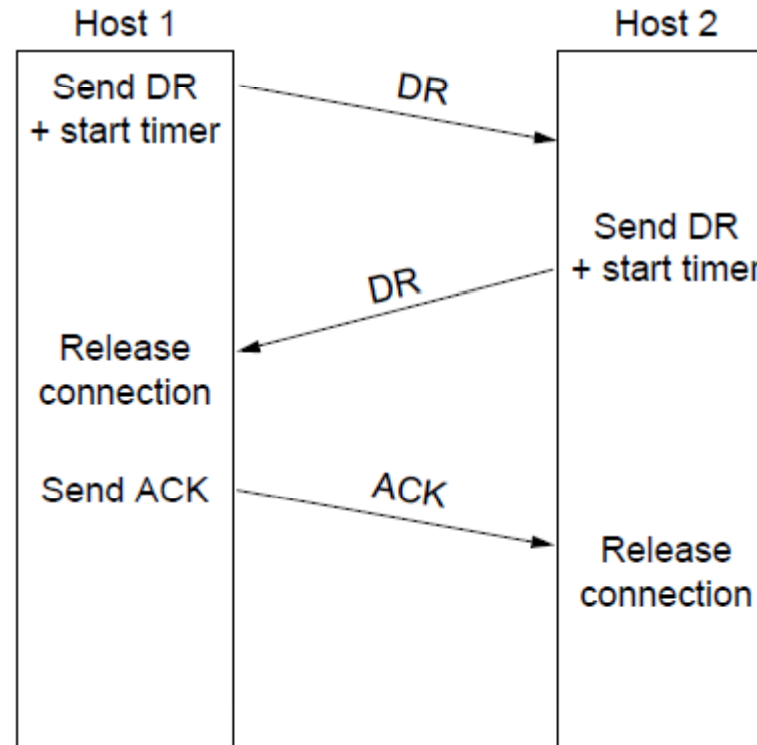

Four protocol scenarios for releasing a connection.

(a) Normal case of three-way handshake

Connection Release (4)

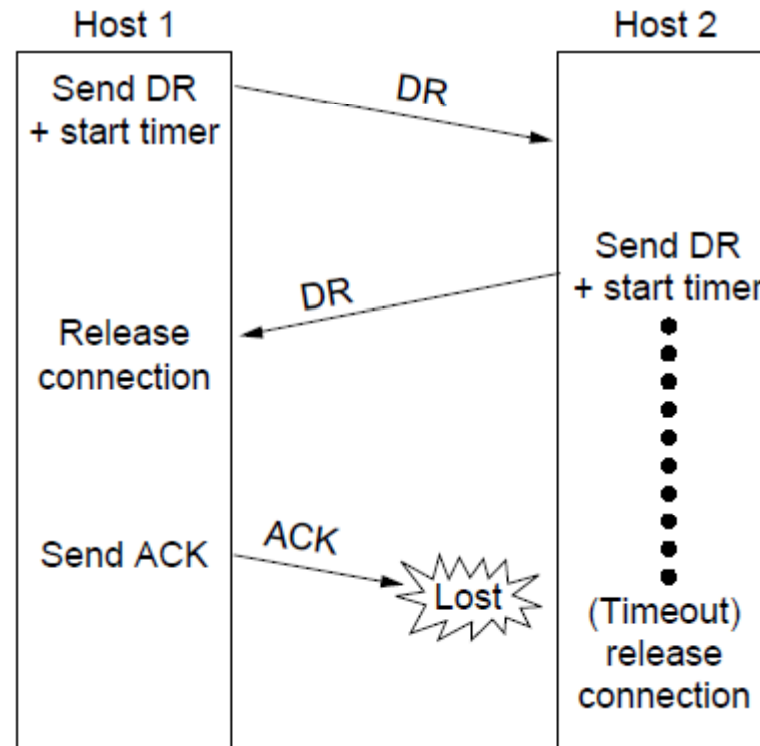

Four protocol scenarios for releasing a connection.
(b) Final ACK lost.

Connection Release (5)

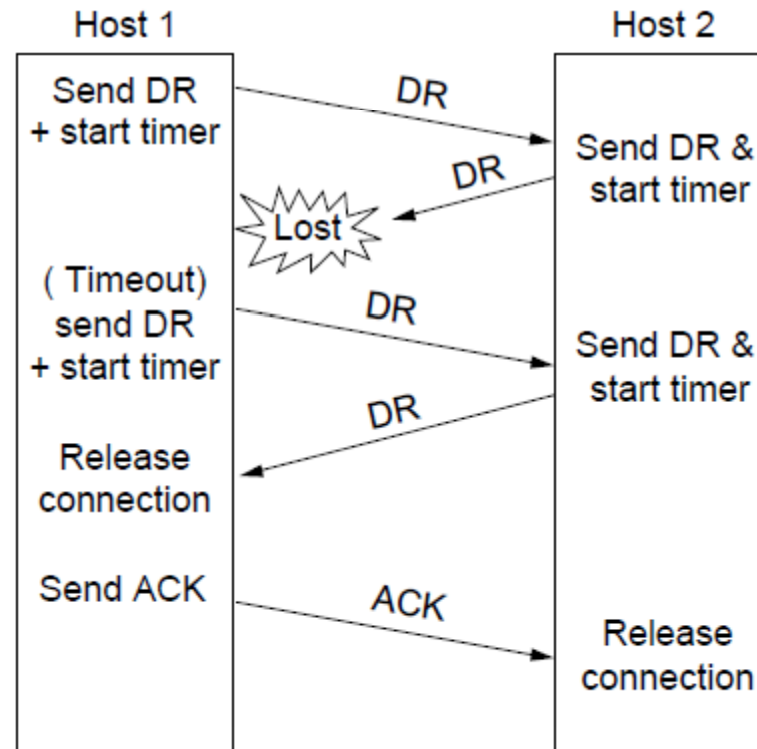

Four protocol scenarios for releasing a connection.
(c) Response lost

Connection Release (6)

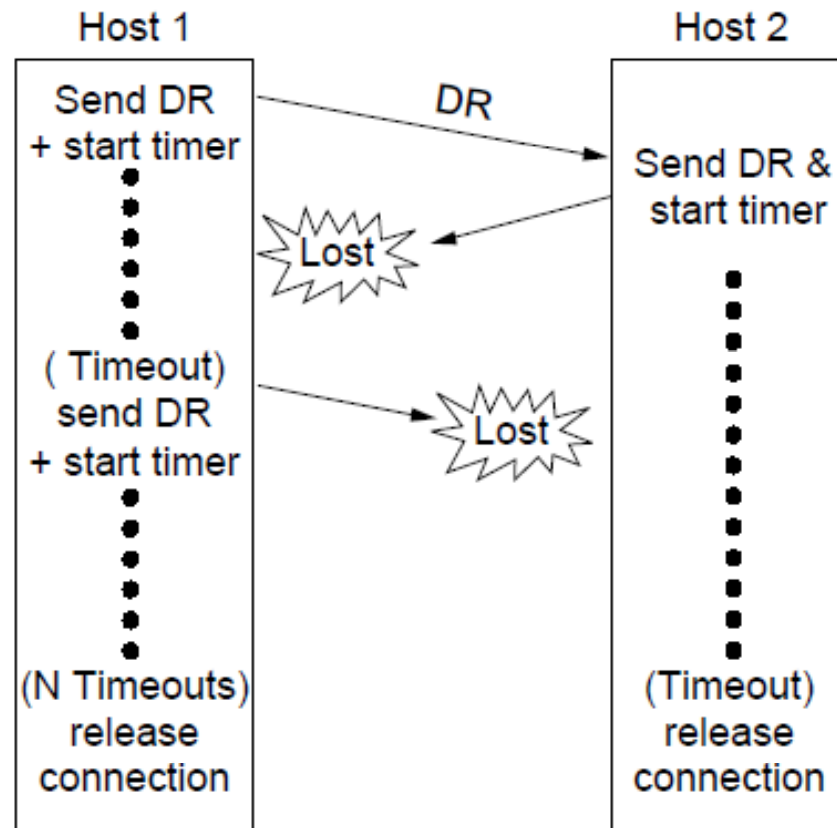

Four protocol scenarios for releasing a connection.
(d) Response lost and subsequent DRs lost.

Error Control and Flow Control (1)

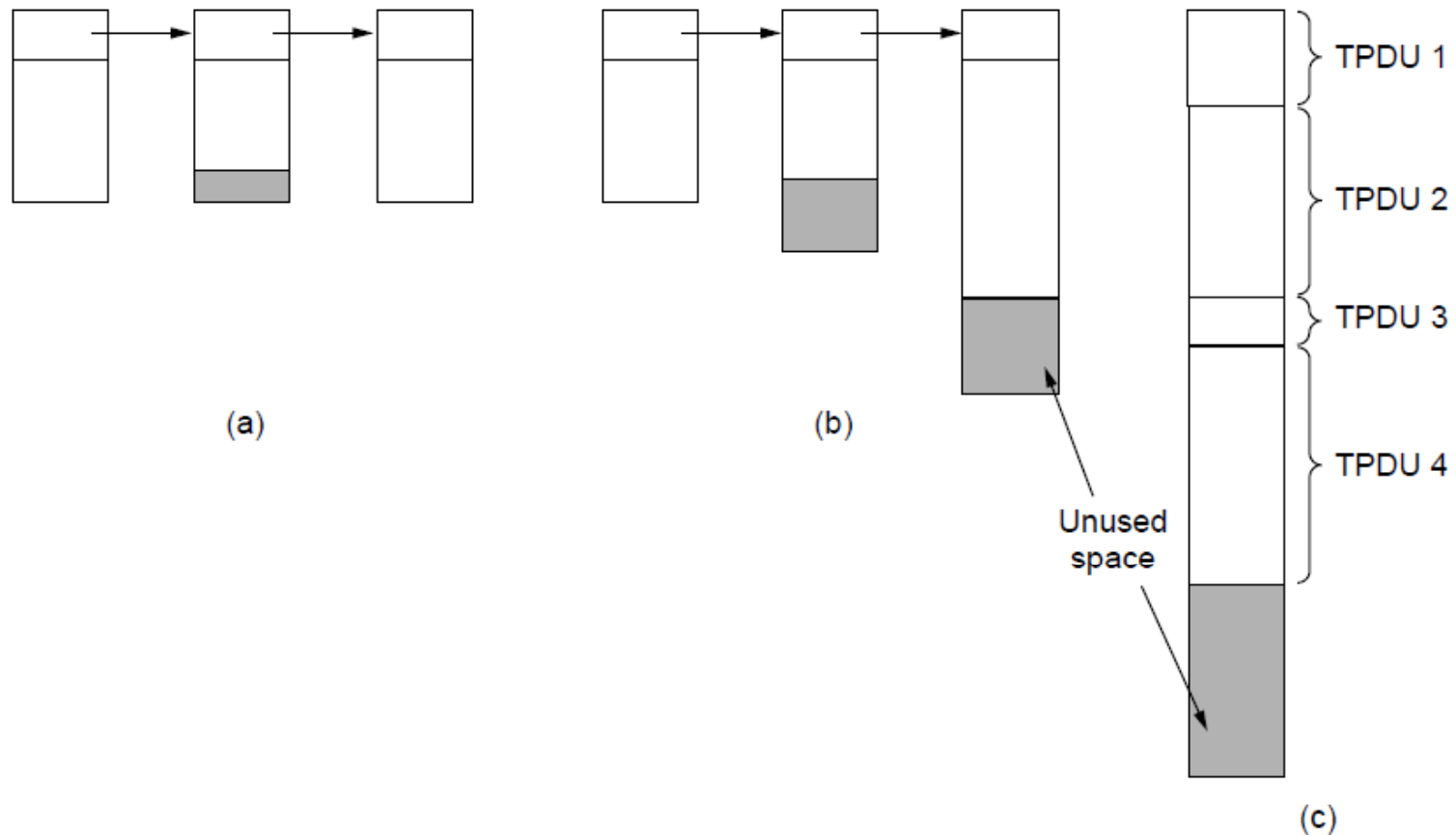

(a) Chained fixed-size buffers. (b) Chained variable-sized buffers. (c) One large circular buffer per connection.

Error Control and Flow Control (2)

	<u>A</u>	<u>Message</u>	<u>B</u>	<u>Comments</u>
1	→	< request 8 buffers>	→	A wants 8 buffers
2	←	<ack = 15, buf = 4>	←	B grants messages 0-3 only
3	→	<seq = 0, data = m0>	→	A has 3 buffers left now
4	→	<seq = 1, data = m1>	→	A has 2 buffers left now
5	→	<seq = 2, data = m2>	•••	Message lost but A thinks it has 1 left
6	←	<ack = 1, buf = 3>	←	B acknowledges 0 and 1, permits 2-4
7	→	<seq = 3, data = m3>	→	A has 1 buffer left
8	→	<seq = 4, data = m4>	→	A has 0 buffers left, and must stop
9	→	<seq = 2, data = m2>	→	A times out and retransmits
10	←	<ack = 4, buf = 0>	←	Everything acknowledged, but A still blocked
11	←	<ack = 4, buf = 1>	←	A may now send 5
12	←	<ack = 4, buf = 2>	←	B found a new buffer somewhere
13	→	<seq = 5, data = m5>	→	A has 1 buffer left
14	→	<seq = 6, data = m6>	→	A is now blocked again
15	←	<ack = 6, buf = 0>	←	A is still blocked
16	•••	<ack = 6, buf = 4>	←	Potential deadlock

Dynamic buffer allocation. The arrows show the direction of transmission. An ellipsis (...) indicates a lost TPDU

Multiplexing

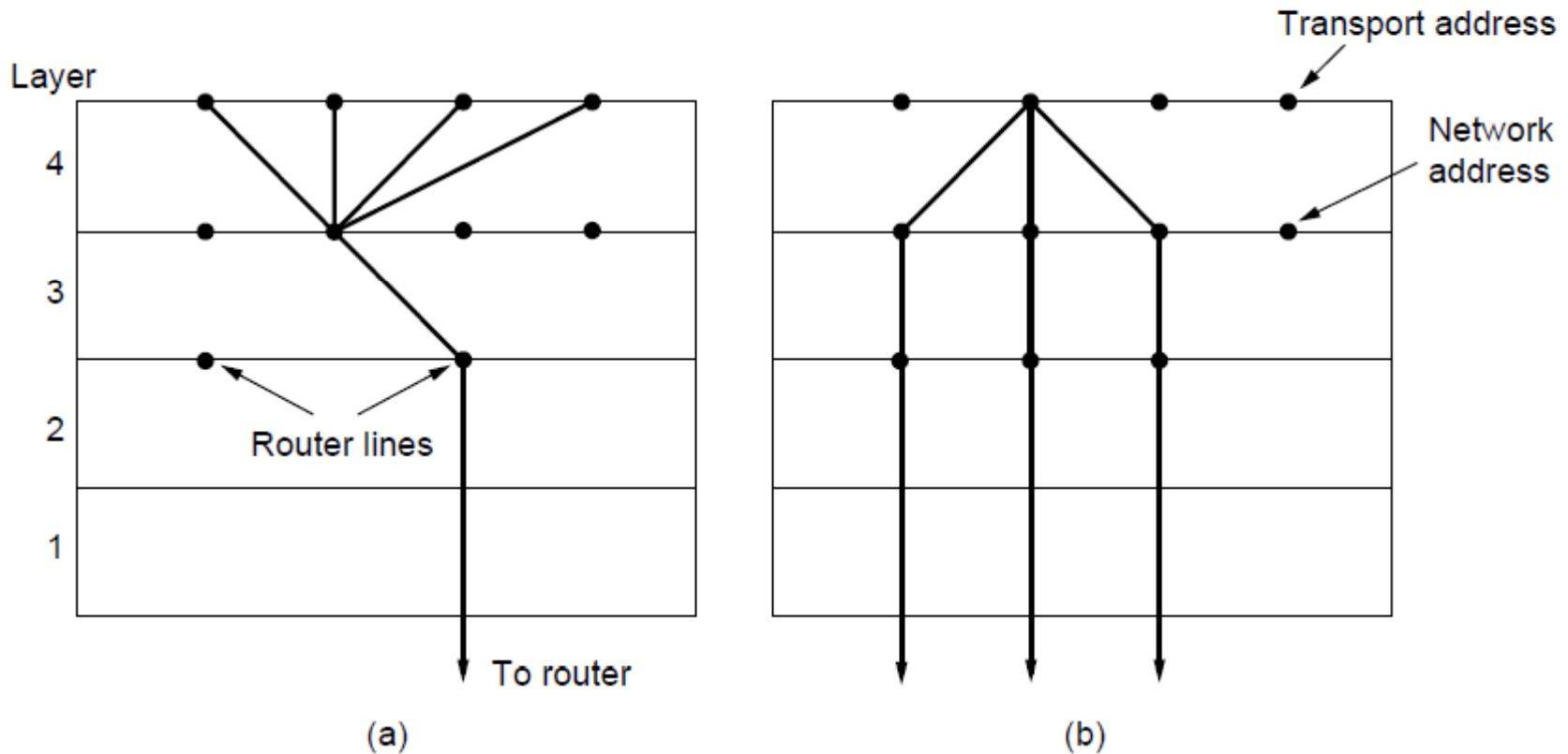

(a) Multiplexing. (b) Inverse multiplexing.

Crash Recovery

Strategy used by sending host	Strategy used by receiving host					
	← First ACK, then write →			← First write, then ACK →		
	AC(W)	AWC	C(AW)	C(WA)	W AC	WC(A)
Always retransmit	OK	DUP	OK	OK	DUP	DUP
Never retransmit	LOST	OK	LOST	LOST	OK	OK
Retransmit in S0	OK	DUP	LOST	LOST	DUP	OK
Retransmit in S1	LOST	OK	OK	OK	OK	DUP

OK = Protocol functions correctly
 DUP = Protocol generates a duplicate message
 LOST = Protocol loses a message

Different combinations of client and server strategy

Congestion Control

- Desirable bandwidth allocation
- Regulating the sending rate

Desirable Bandwidth Allocation (1)

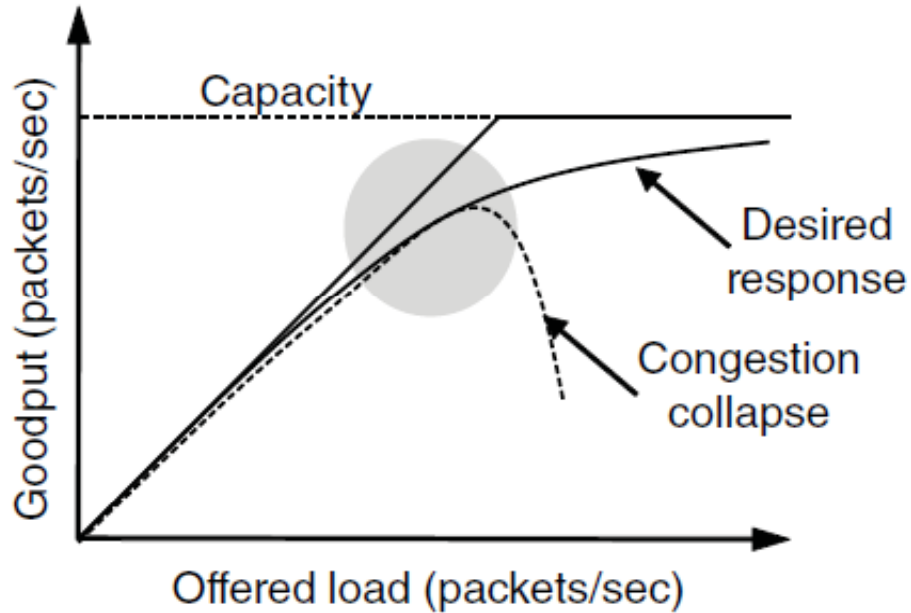

(a)

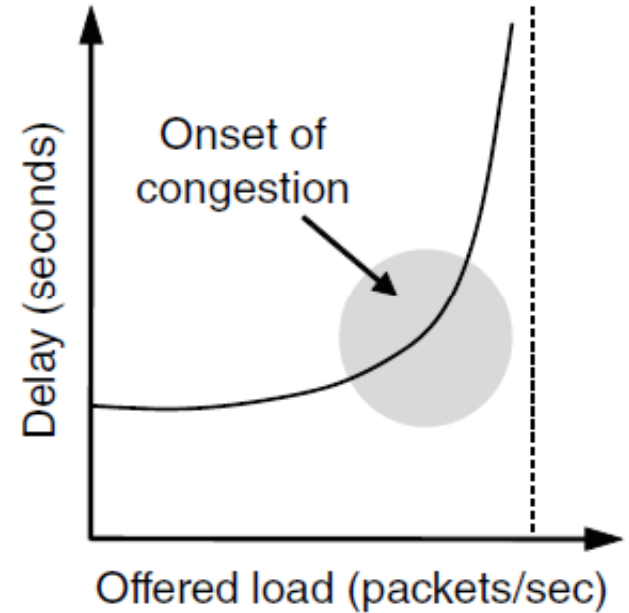

(b)

(a) Goodput and (b) delay as a function of offered load

Desirable Bandwidth Allocation (2)

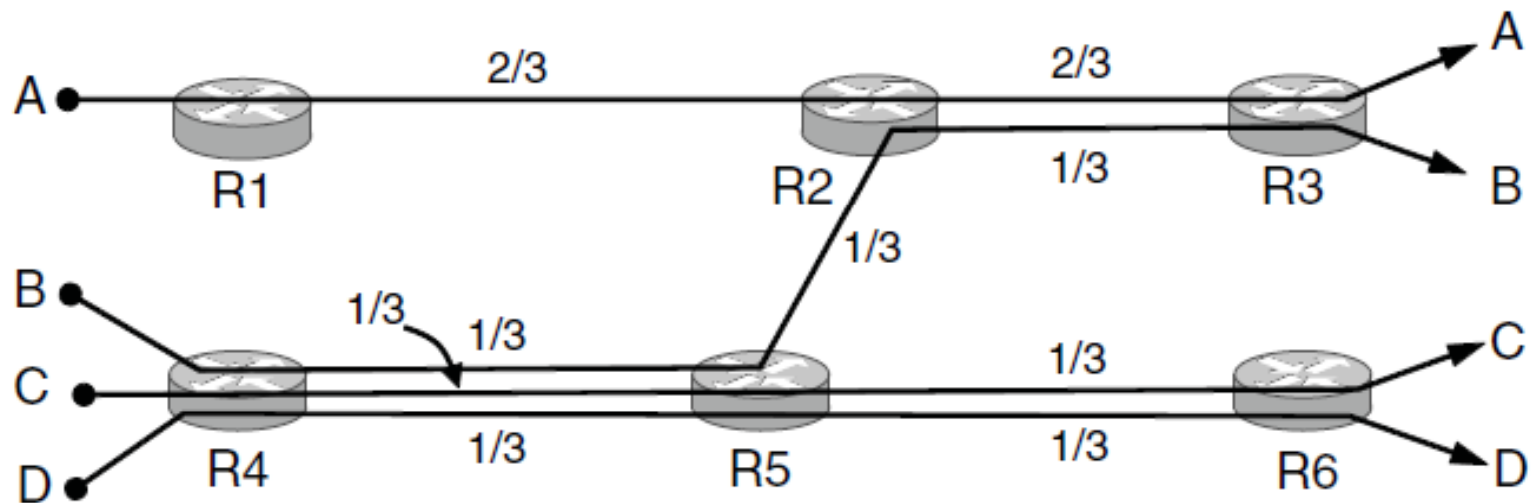

Max-min bandwidth allocation for four flows

Desirable Bandwidth Allocation (3)

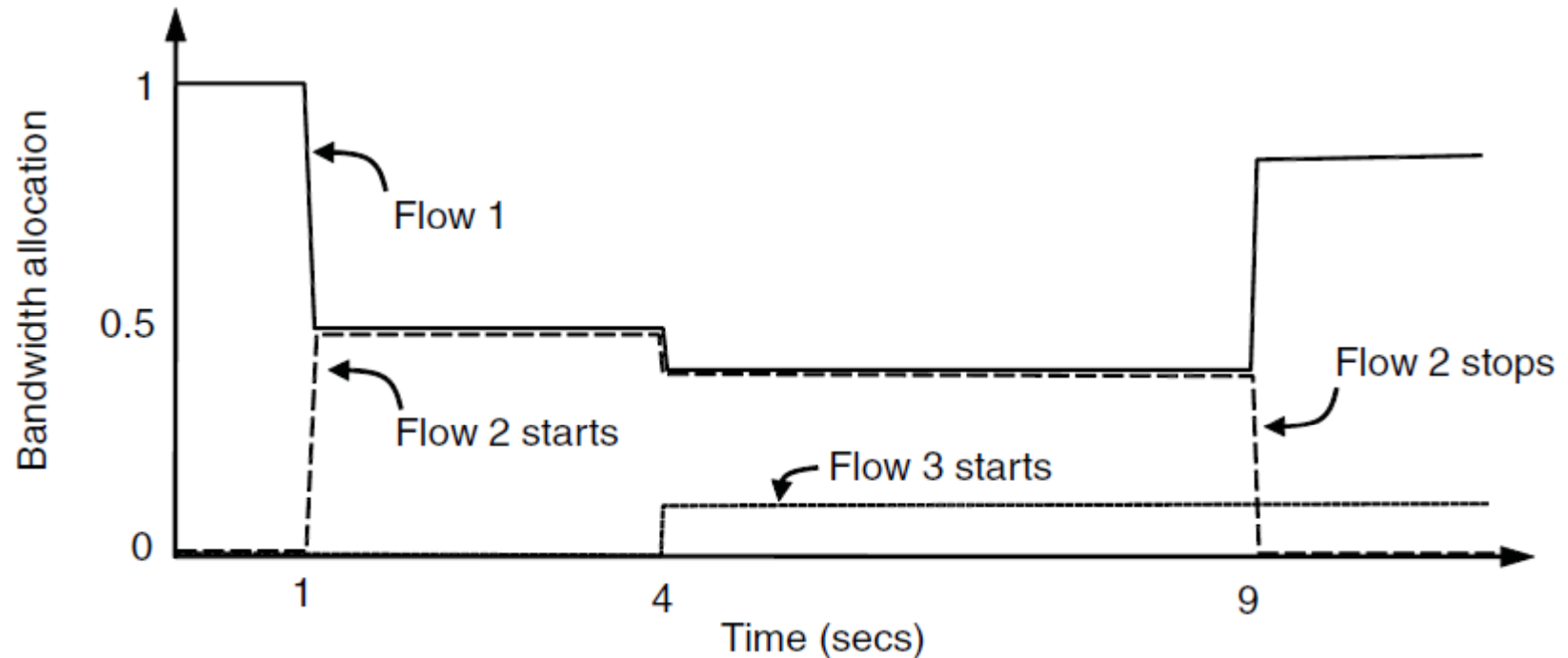

Changing bandwidth allocation over time

Regulating the Sending Rate (1)

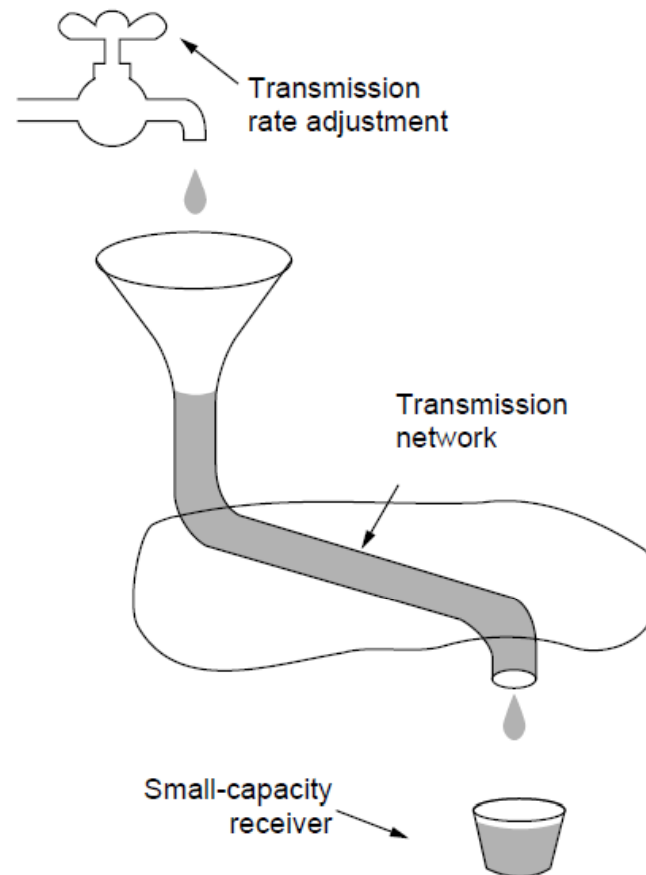

A fast network feeding a low-capacity receiver

Regulating the Sending Rate (2)

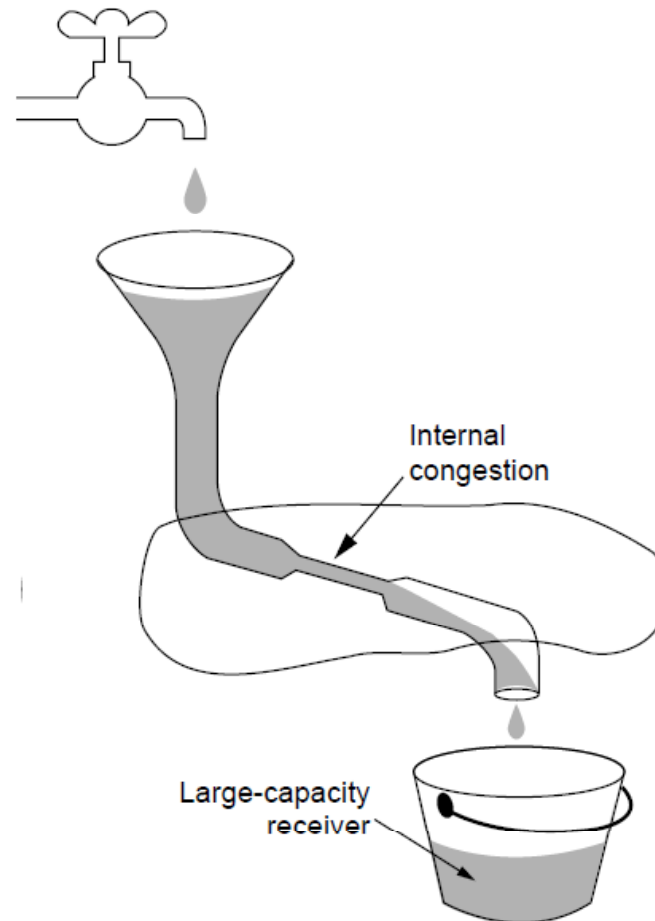

A slow network feeding a high-capacity receiver

Regulating the Sending Rate (3)

Protocol	Signal	Explicit?	Precise?
XCP	Rate to use	Yes	Yes
TCP with ECN	Congestion warning	Yes	No
FAST TCP	End-to-end delay	No	Yes
CUBIC TCP	Packet loss	No	No
TCP	Packet loss	No	No

Some congestion control protocols

Regulating the Sending Rate (4)

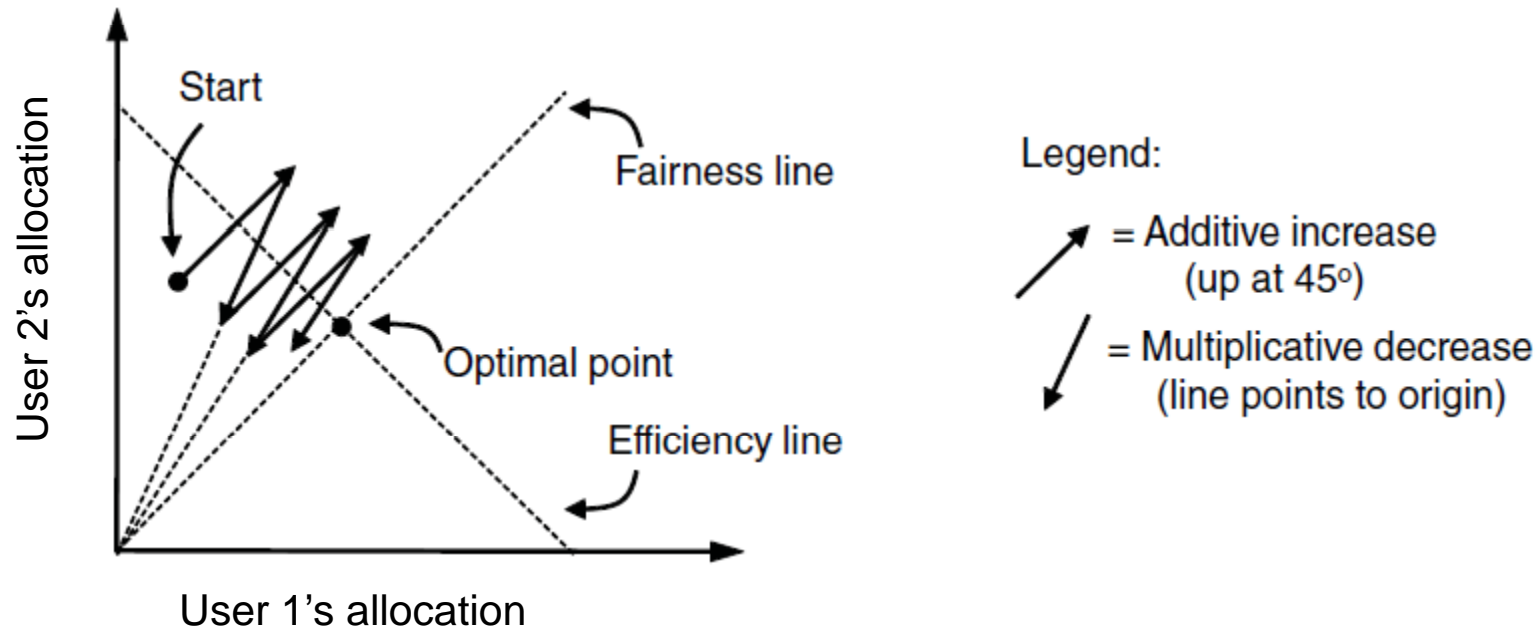

Additive Increase Multiplicative Decrease (AIMD) control law.

The Internet Transport Protocols: UDP

- Introduction to UDP
- Remote Procedure Call
- Real-Time Transport

Introduction to UDP (1)

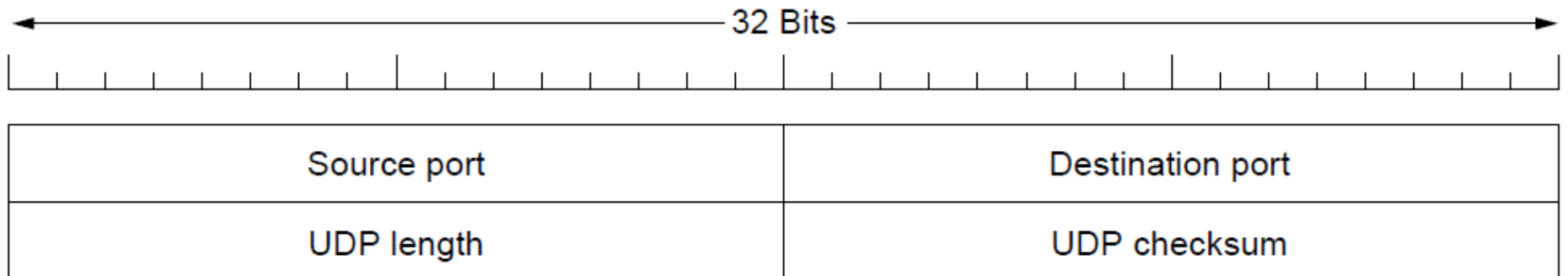

The UDP header.

Introduction to UDP (2)

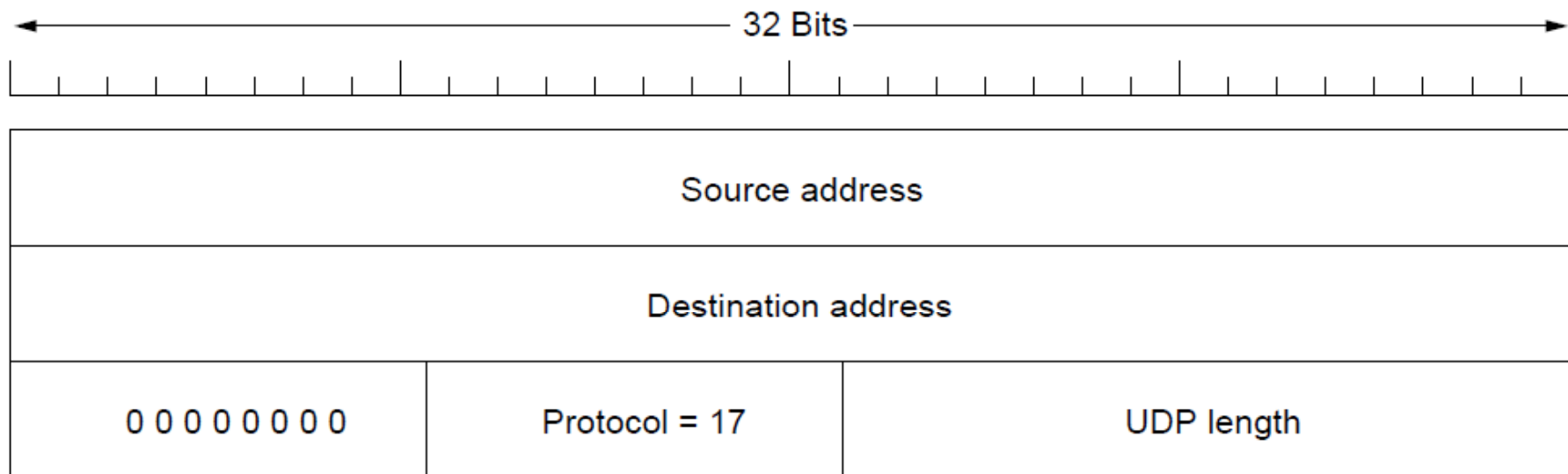

The IPv4 pseudoheader included in the UDP checksum.

Remote Procedure Call

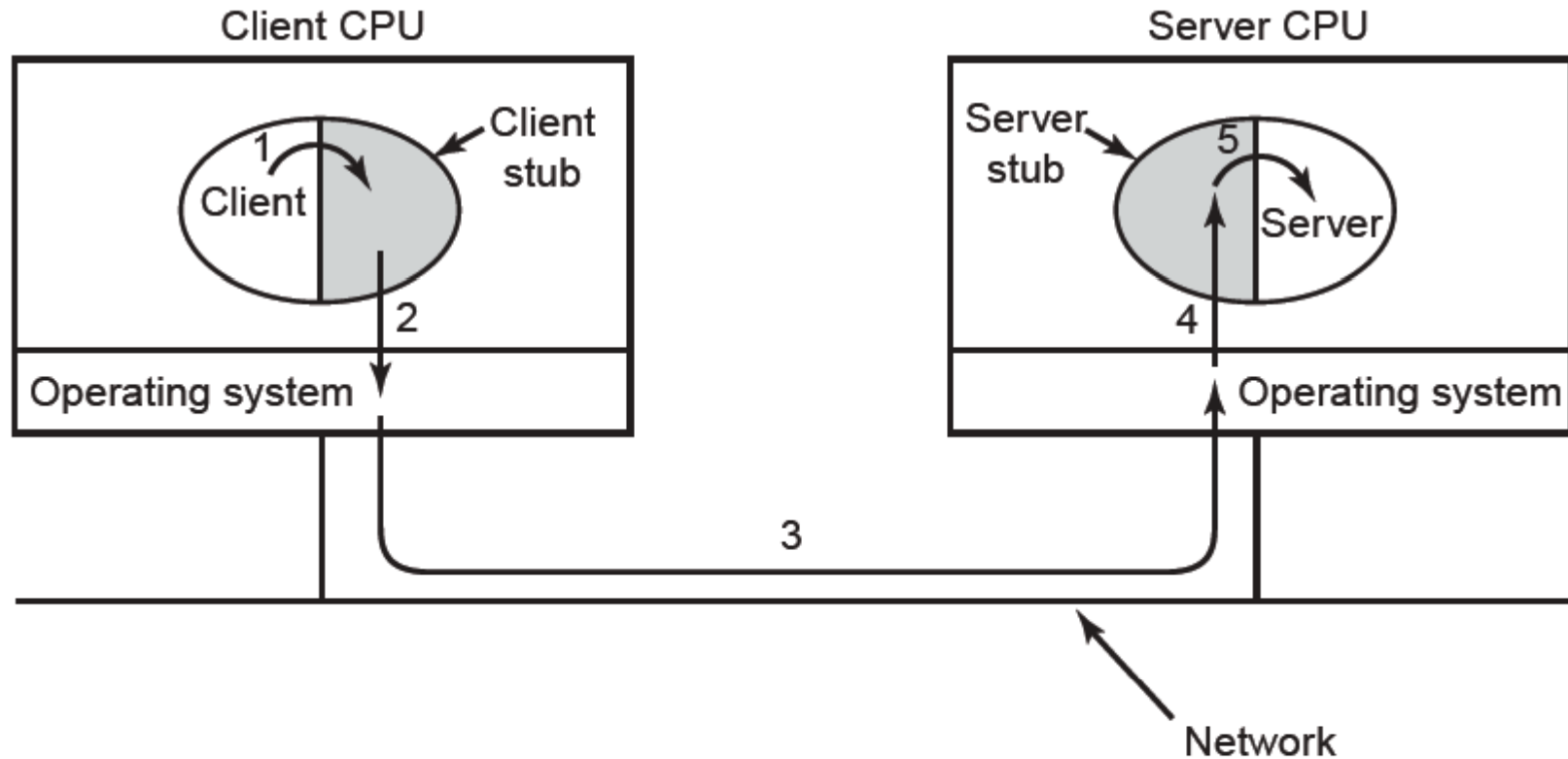

Steps in making a remote procedure call. The stubs are shaded.

Real-Time Transport (1)

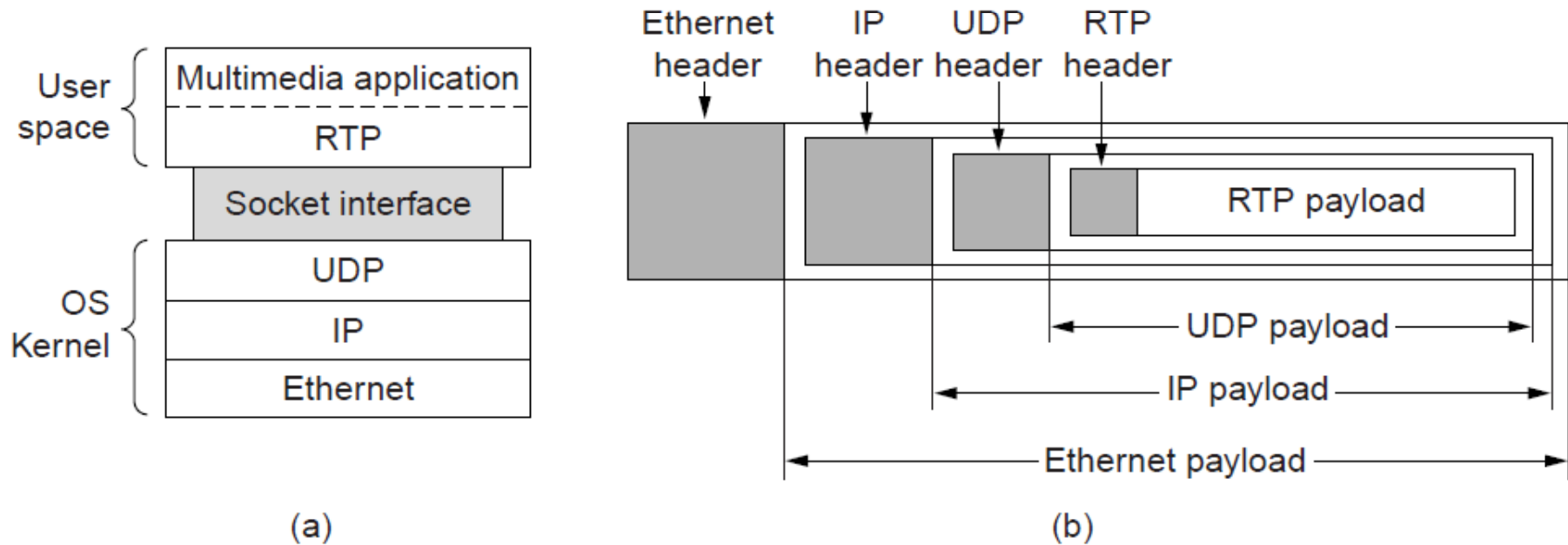

(a) The position of RTP in the protocol stack. (b) Packet nesting.

Real-Time Transport (2)

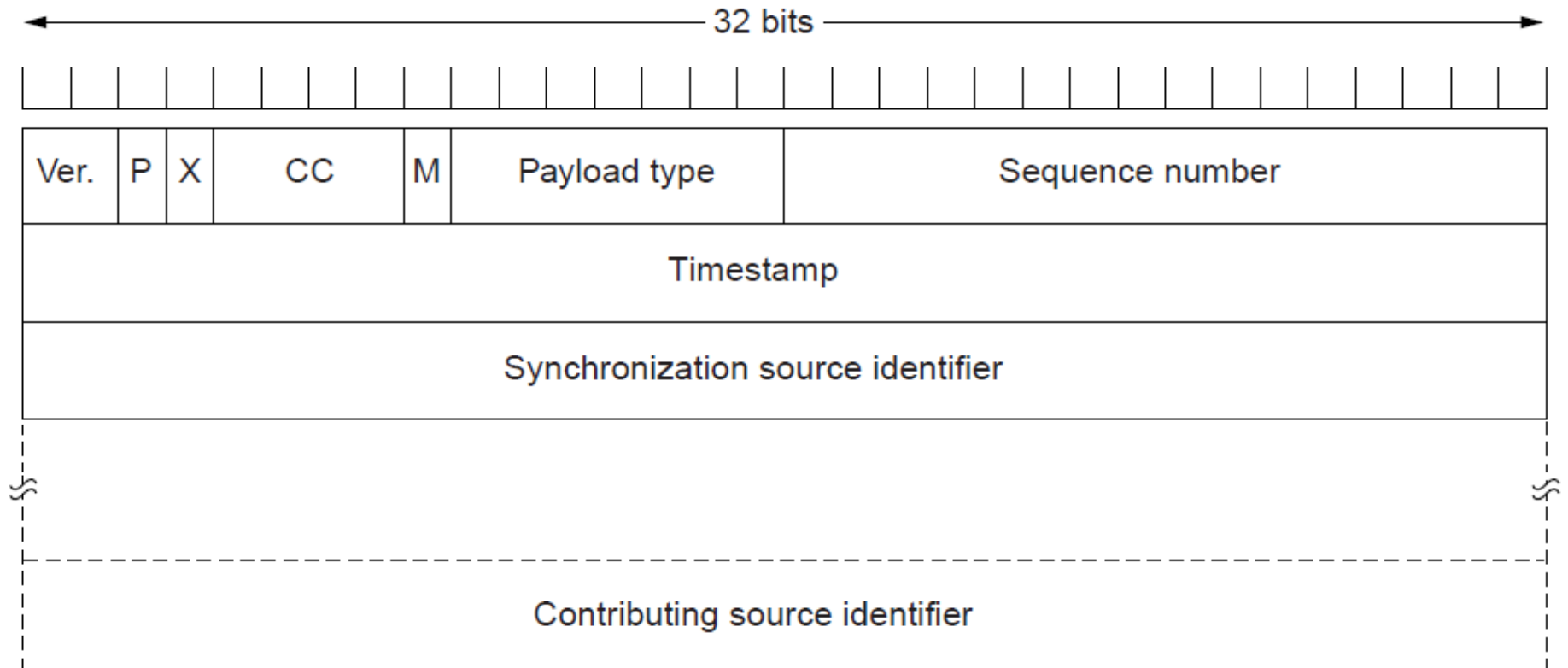

The RTP header

Real-Time Transport (3)

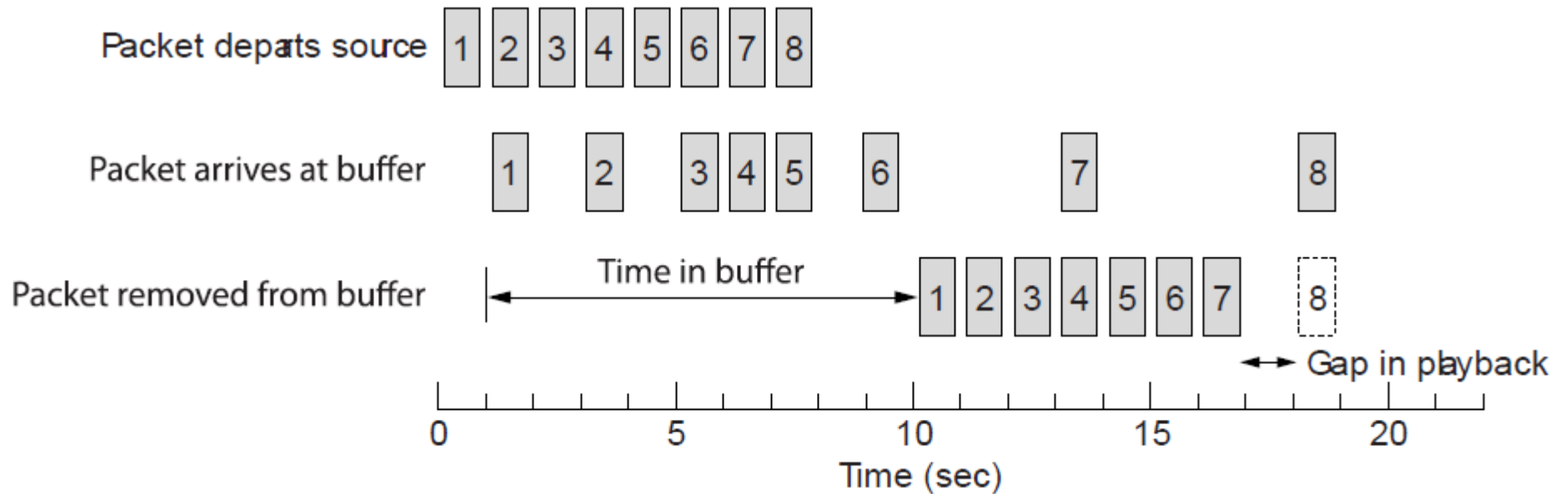

Smoothing the output stream by buffering packets

Real-Time Transport (3)

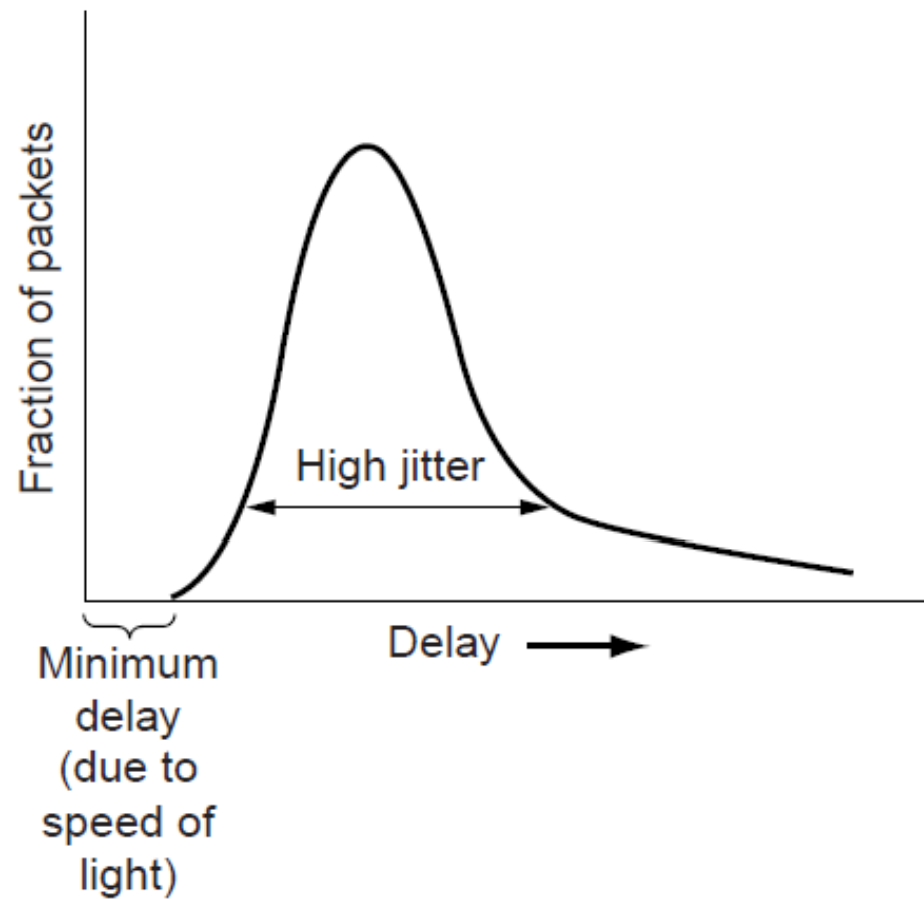

High jitter

Real-Time Transport (4)

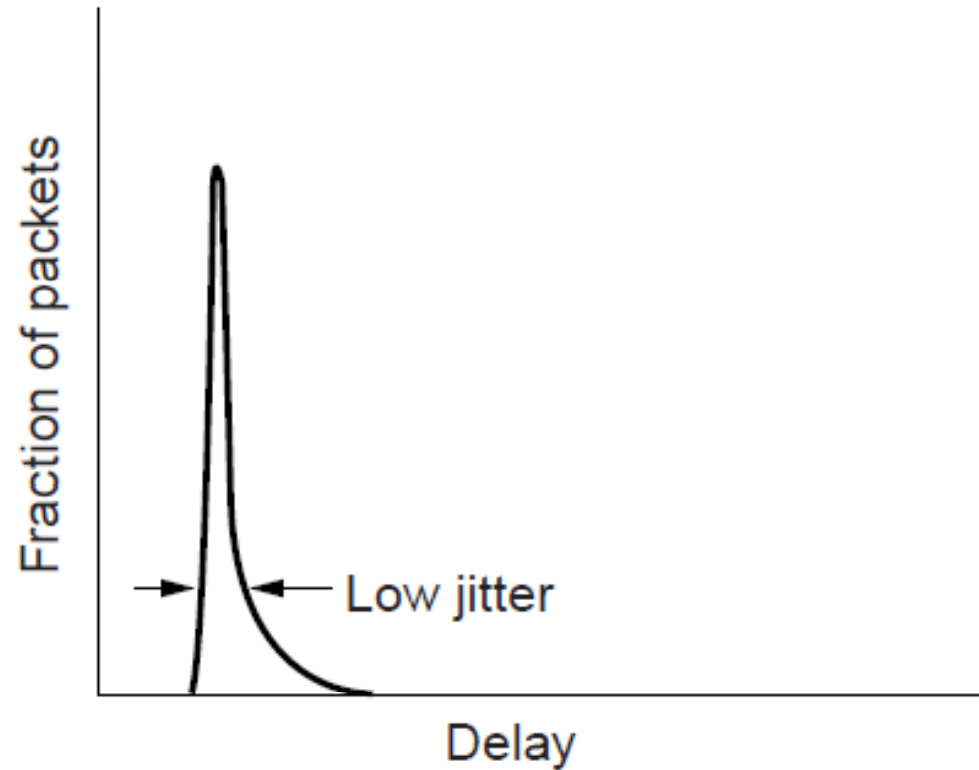

Low jitter

The Internet Transport Protocols: TCP (1)

- Introduction to TCP
- The TCP service model
- The TCP protocol
- The TCP segment header
- TCP connection establishment
- TCP connection release

The Internet Transport Protocols: TCP (2)

- TCP connection management modeling
- TCP sliding window
- TCP timer management
- TCP congestion control
- TCP futures

The TCP Service Model (1)

Port	Protocol	Use
20, 21	FTP	File transfer
22	SSH	Remote login, replacement for Telnet
25	SMTP	Email
80	HTTP	World Wide Web
110	POP-3	Remote email access
143	IMAP	Remote email access
443	HTTPS	Secure Web (HTTP over SSL/TLS)
543	RTSP	Media player control
631	IPP	Printer sharing

Some assigned ports

The TCP Service Model (2)

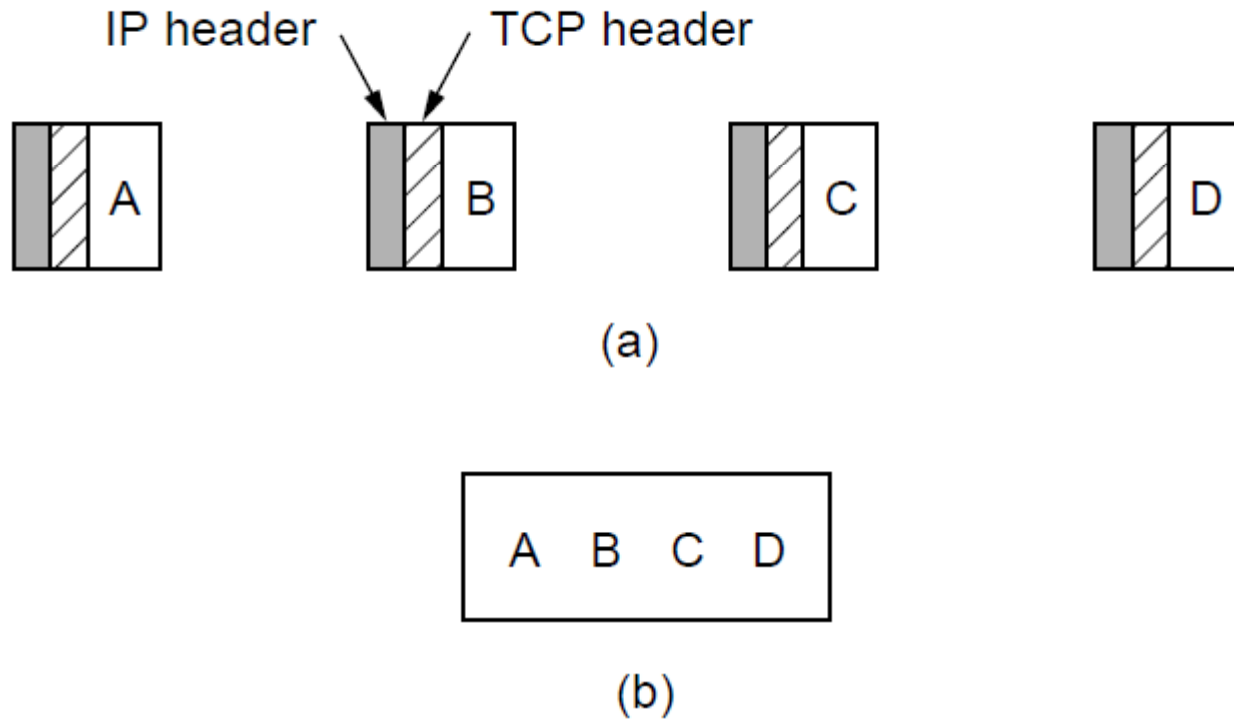

- (a) Four 512-byte segments sent as separate IP diagrams
- (b) The 2048 bytes of data delivered to the application in a single READ call

The TCP Segment Header

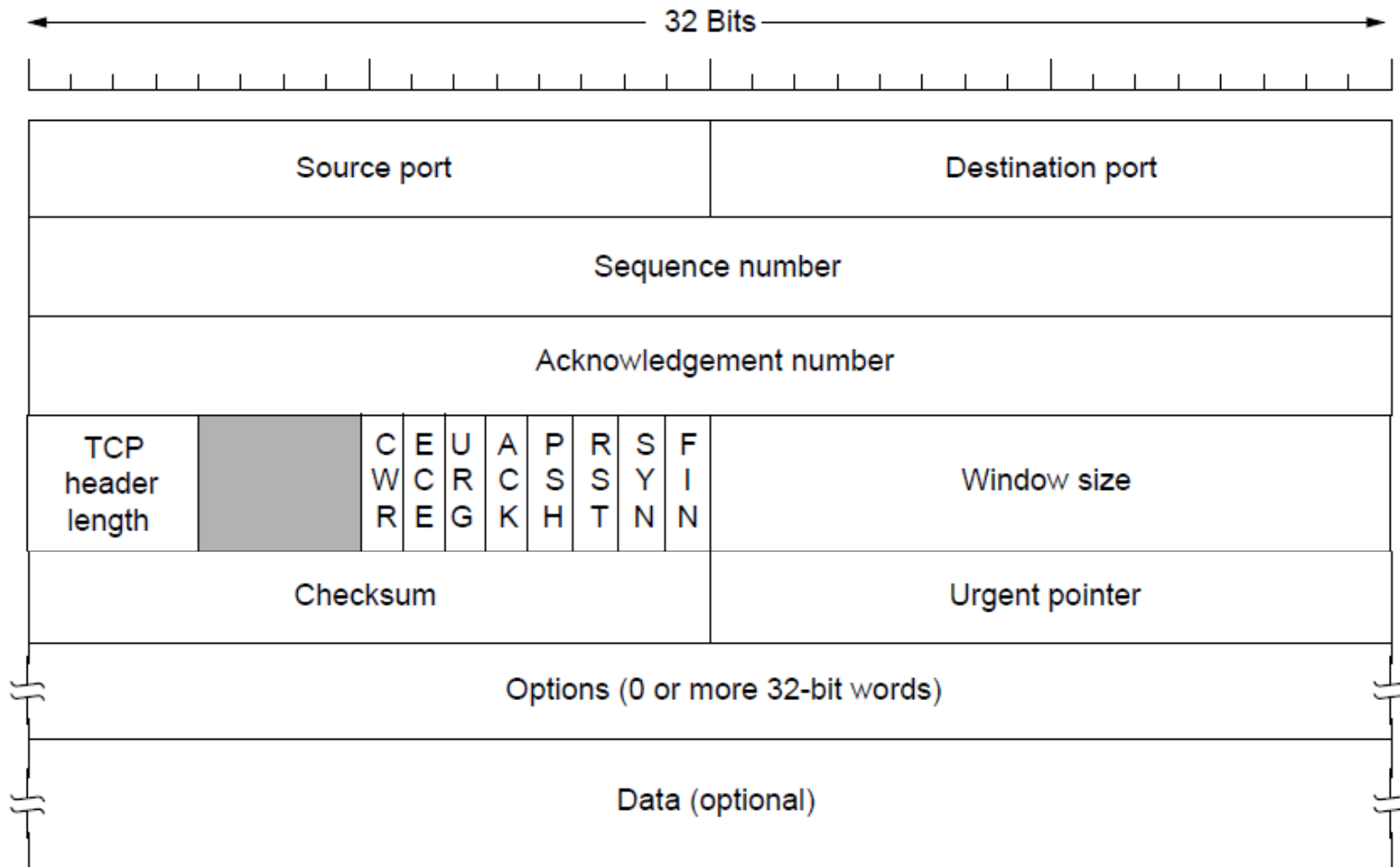

The TCP header.

TCP Connection Establishment

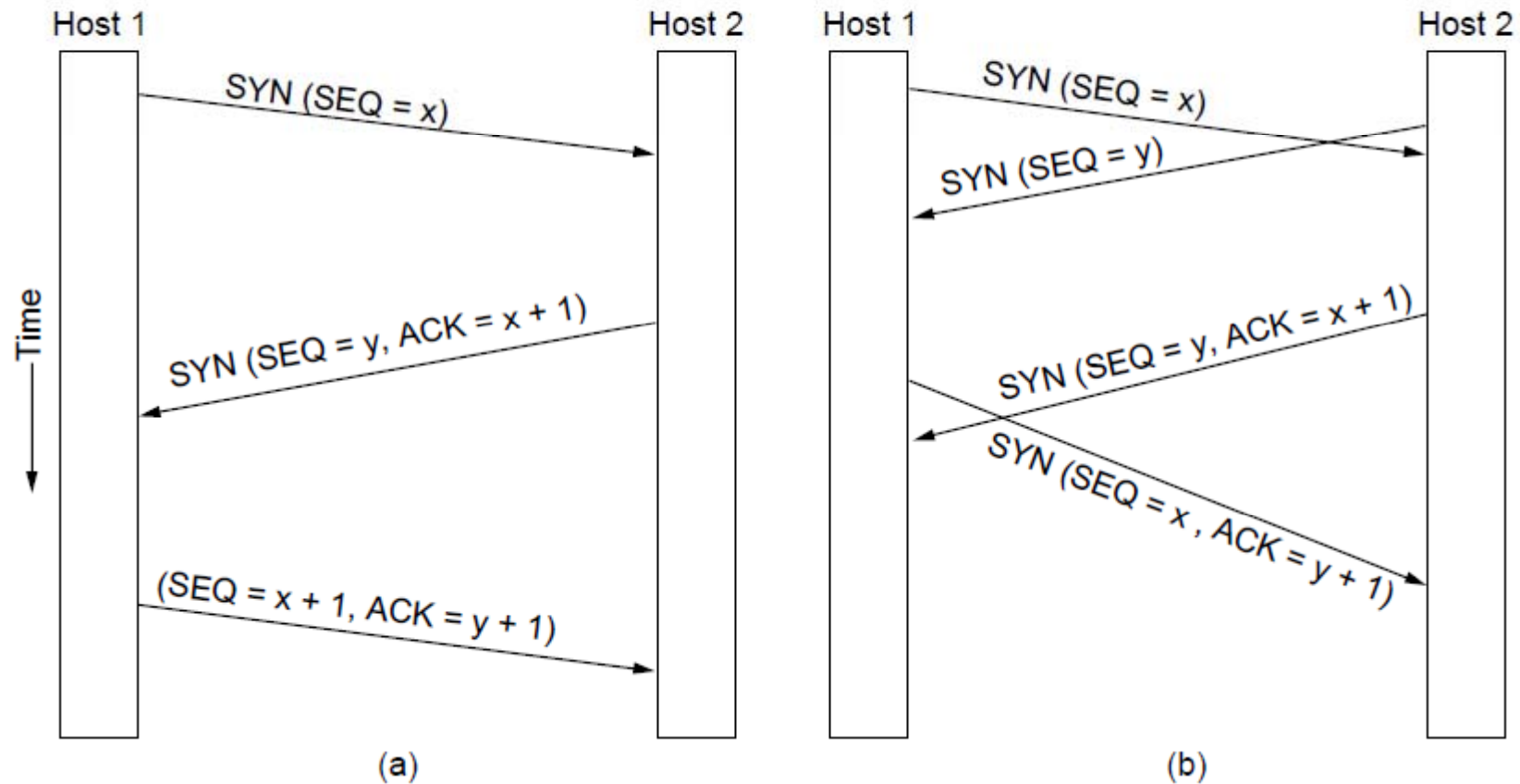

- (a) TCP connection establishment in the normal case.
- (b) Simultaneous connection establishment on both sides.

TCP Connection Management Modeling (1)

State	Description
CLOSED	No connection is active or pending
LISTEN	The server is waiting for an incoming call
SYN RCVD	A connection request has arrived; wait for ACK
SYN SENT	The application has started to open a connection
ESTABLISHED	The normal data transfer state
FIN WAIT 1	The application has said it is finished
FIN WAIT 2	The other side has agreed to release
TIME WAIT	Wait for all packets to die off
CLOSING	Both sides have tried to close simultaneously
CLOSE WAIT	The other side has initiated a release
LAST ACK	Wait for all packets to die off

The states used in the TCP connection management finite state machine.

TCP Sliding Window (1)

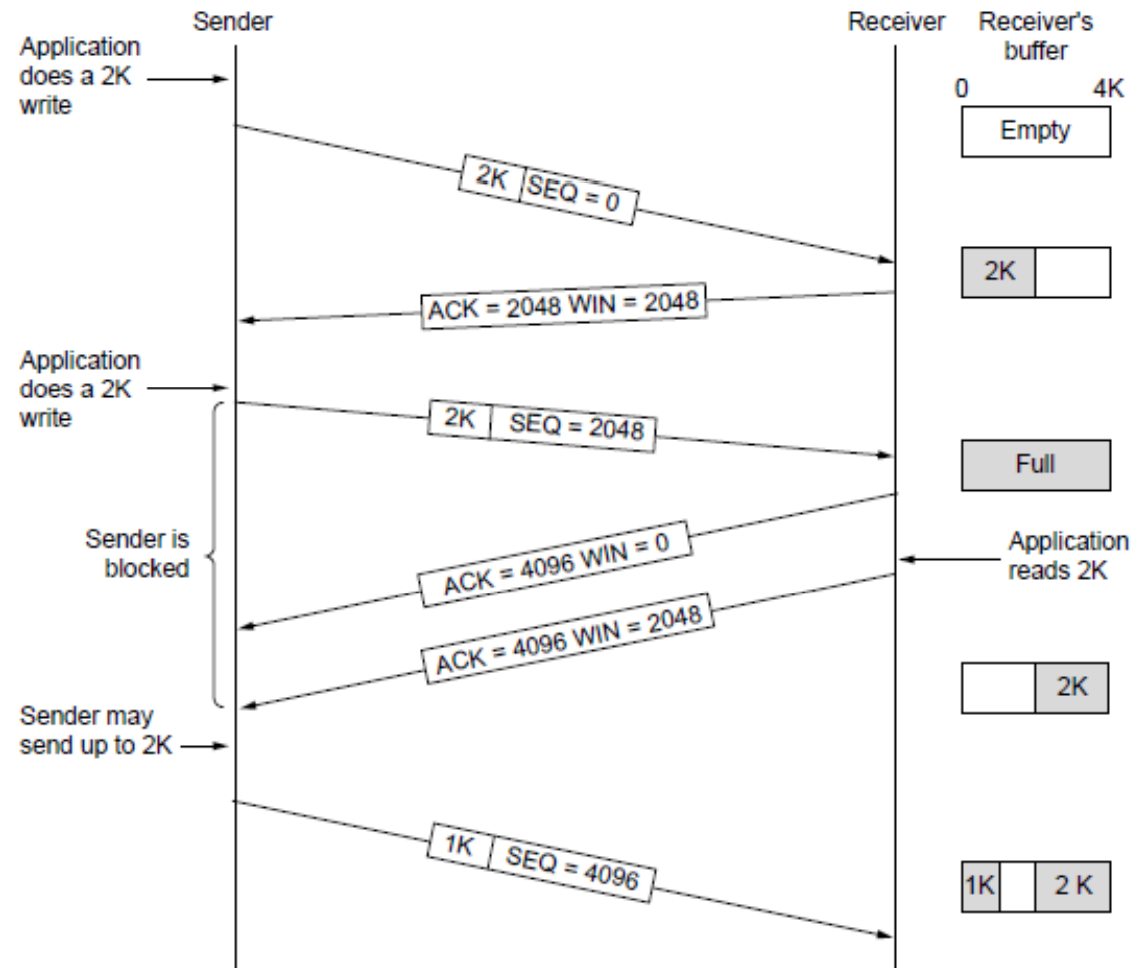

Window management in TCP

TCP Sliding Window (2)

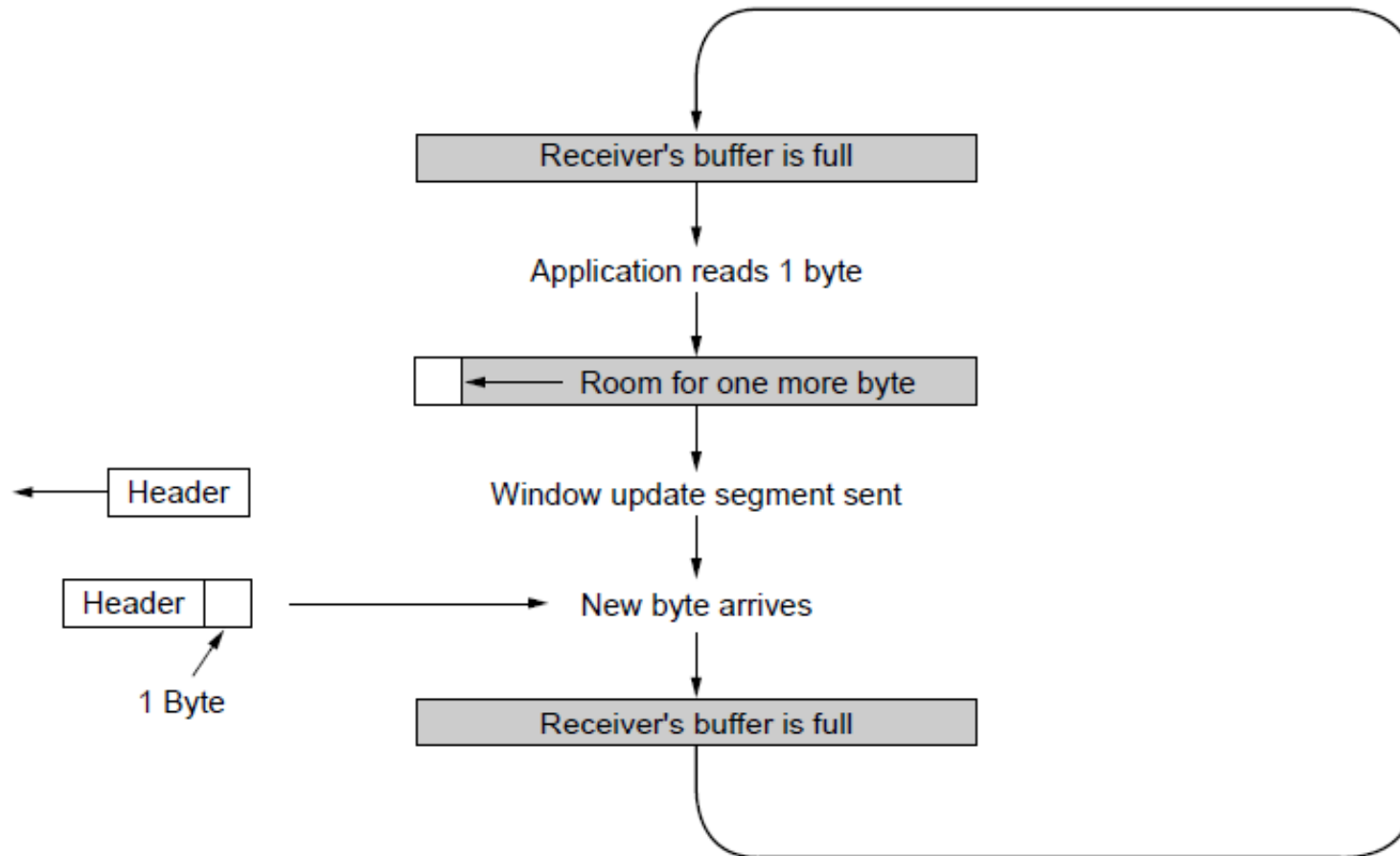

Silly window syndrome

TCP Timer Management

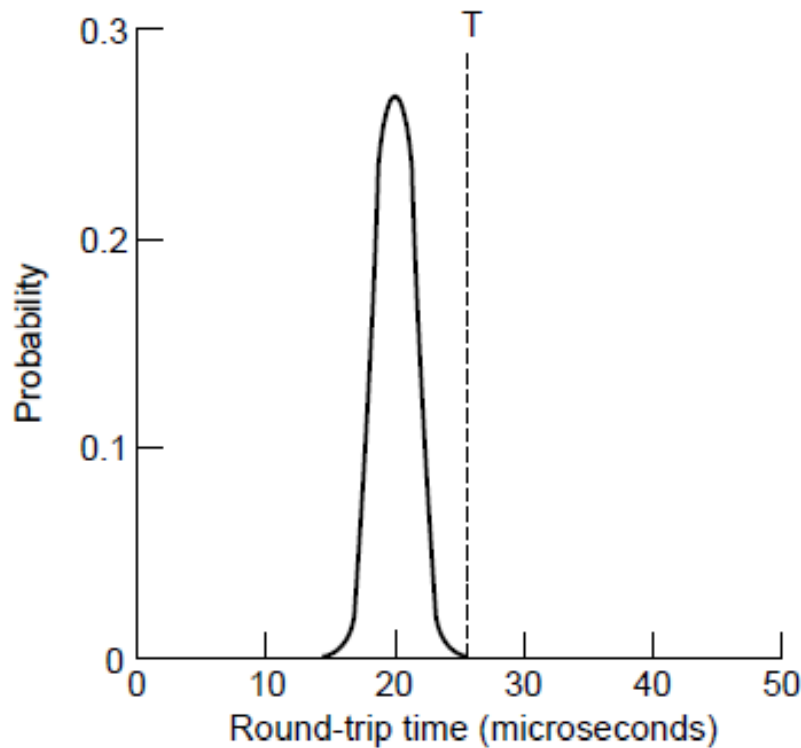

(a)

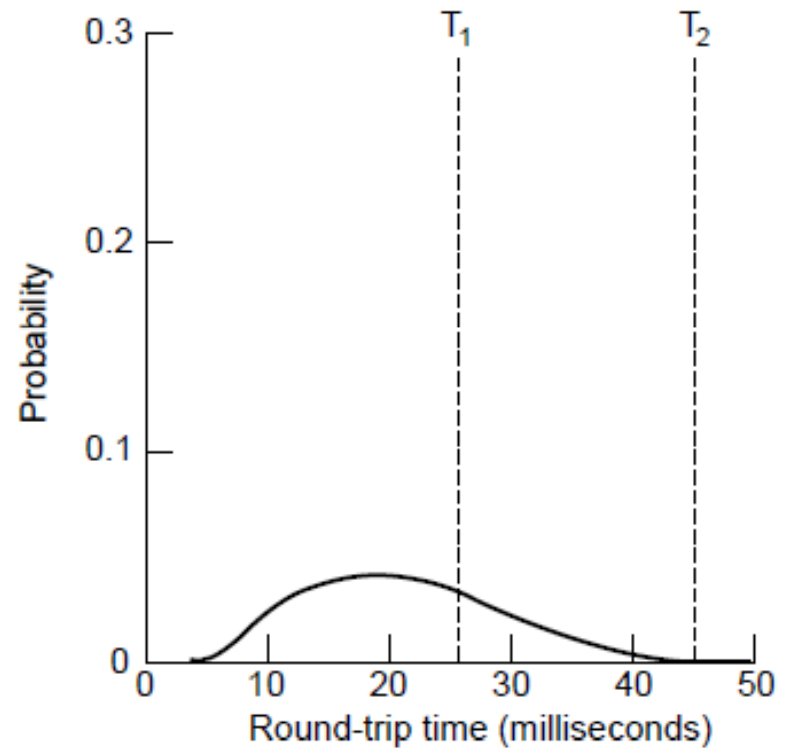

(b)

- (a) Probability density of acknowledgment arrival times in data link layer. (b) ... for TCP

TCP Congestion Control (1)

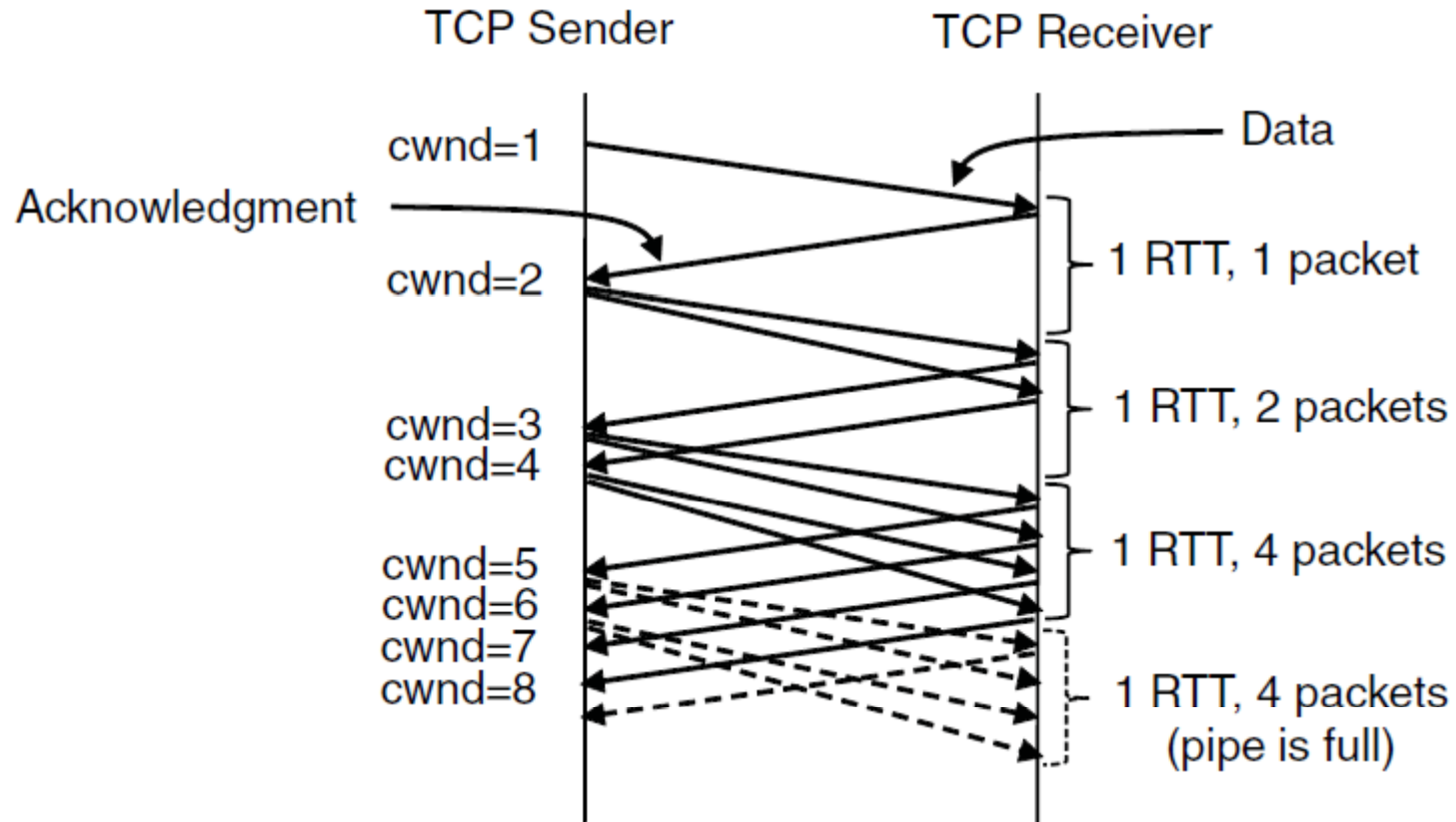

Slow start from an initial congestion window of 1 segment

TCP Congestion Control (2)

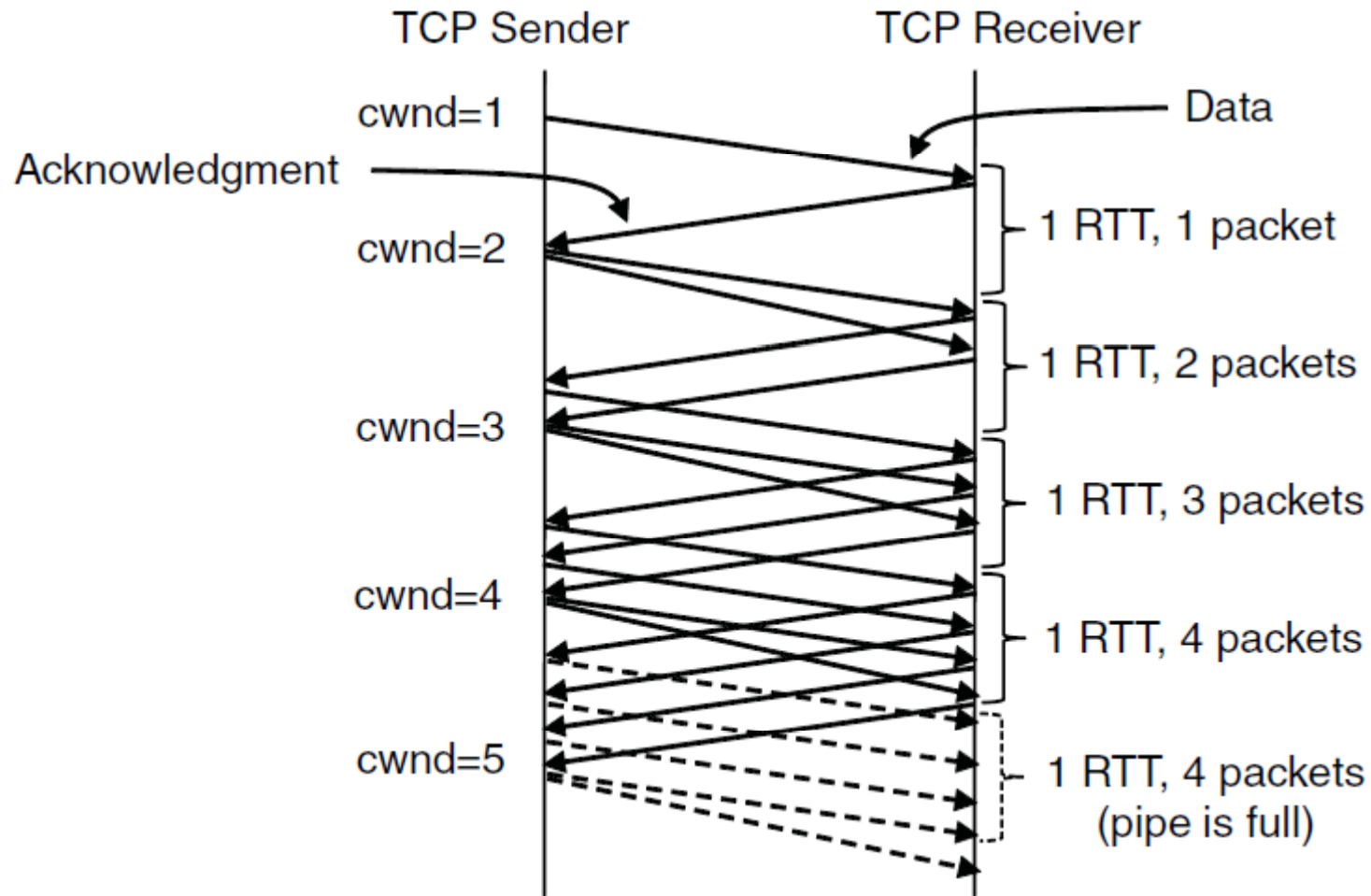

Additive increase from an initial congestion window of 1 segment.

TCP Congestion Control (3)

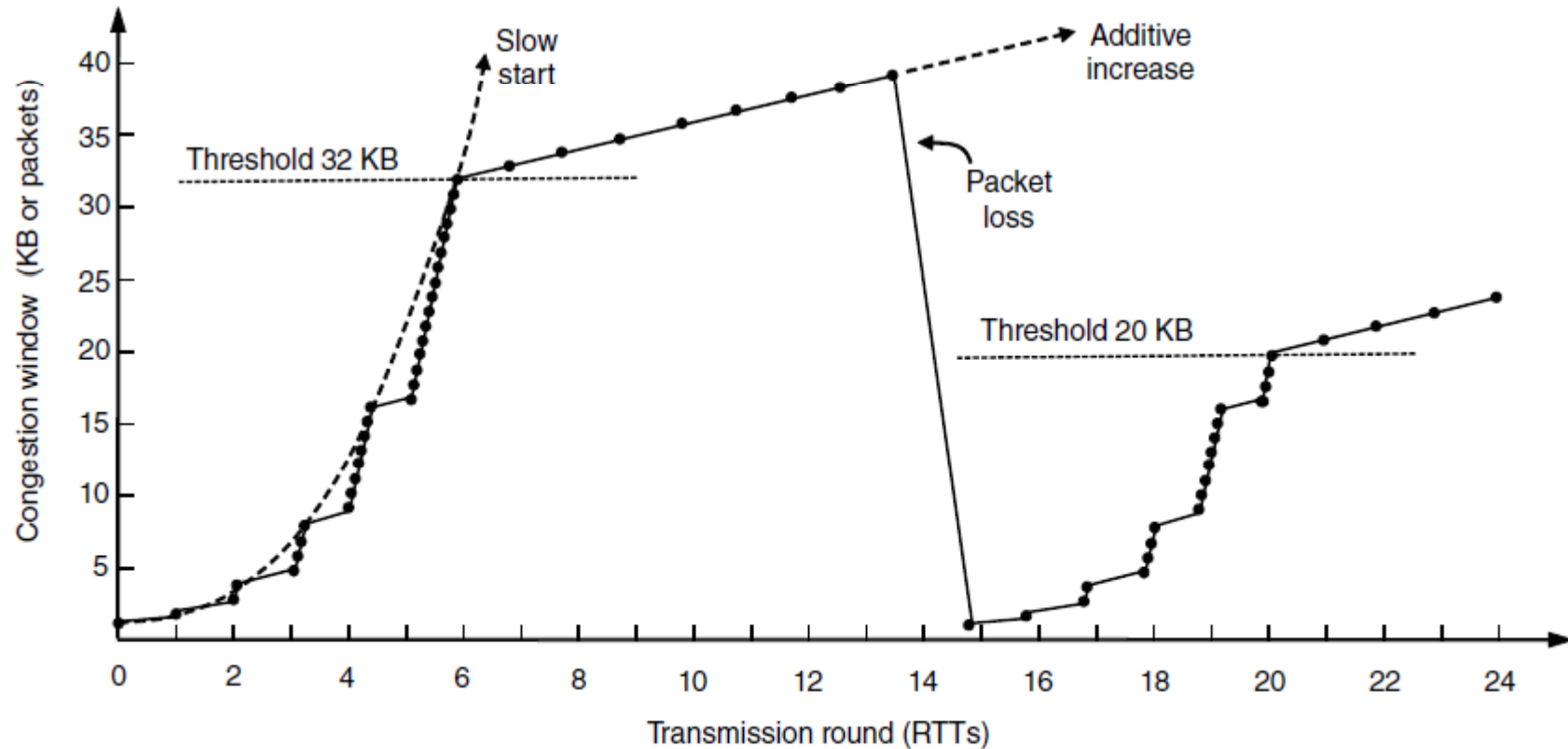

Slow start followed by additive increase in TCP Tahoe.

TCP Congestion Control (4)

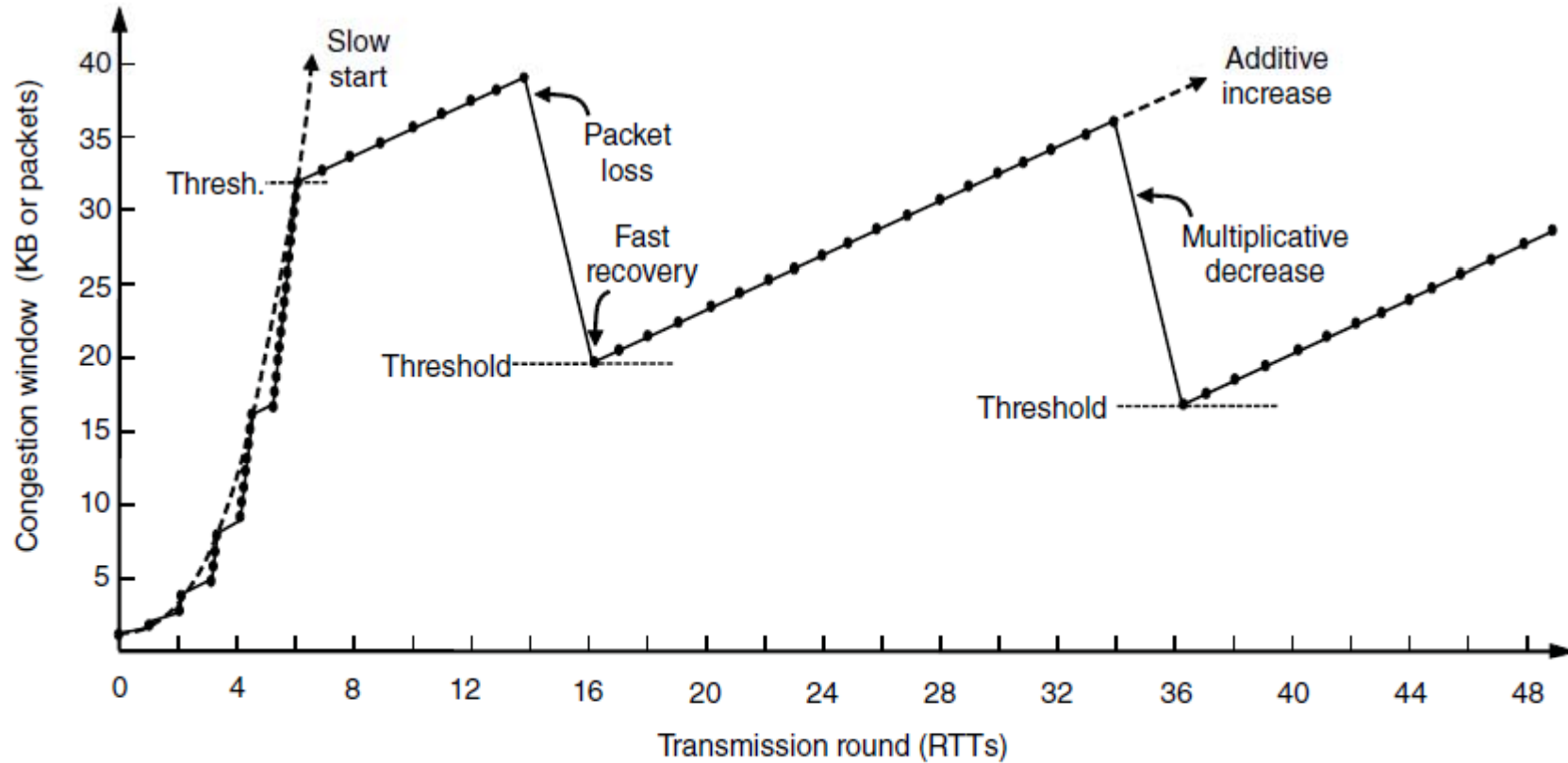

Fast recovery and the sawtooth pattern of TCP Reno.

Performance Issues

- Performance problems in computer networks
- Network performance measurement
- System design for better performance
- Fast TPDU processing
- Protocols for high-speed networks

Performance Problems in Computer Networks

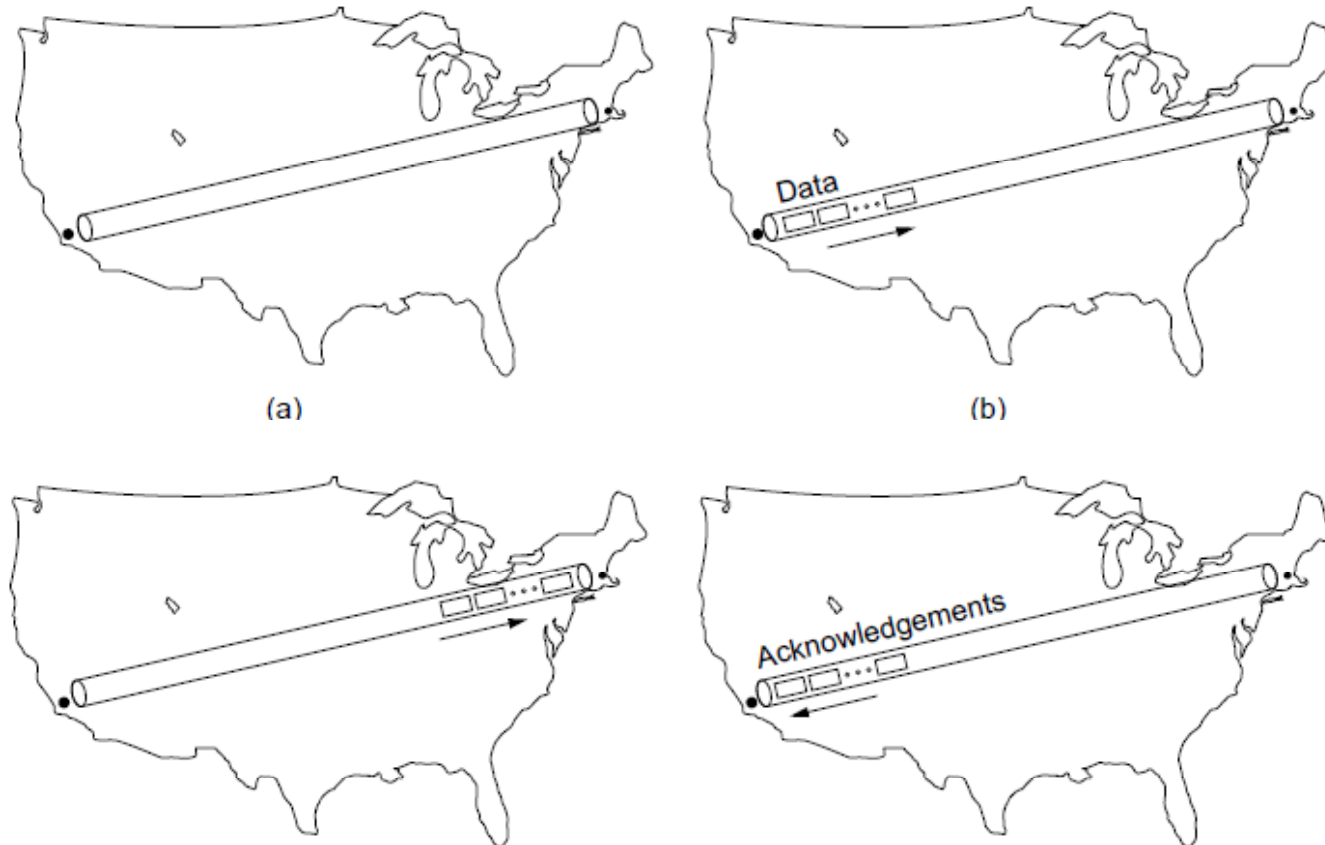

The state of transmitting one megabit from San Diego to Boston.

(a) At $t = 0$. (b) After $500 \mu\text{sec}$.

(c) After 20msec . (d) After 40msec .

Network Performance Measurement (1)

Steps to performance improvement

1. Measure relevant network parameters, performance.
2. Try to understand what is going on.
3. Change one parameter.

Network Performance Measurement (2)

Issues in measuring performance

- Sufficient sample size
- Representative samples
- Clock accuracy
- Measuring typical representative load
- Beware of caching
- Understand what you are measuring
- Extrapolate with care

Network Performance Measurement (3)

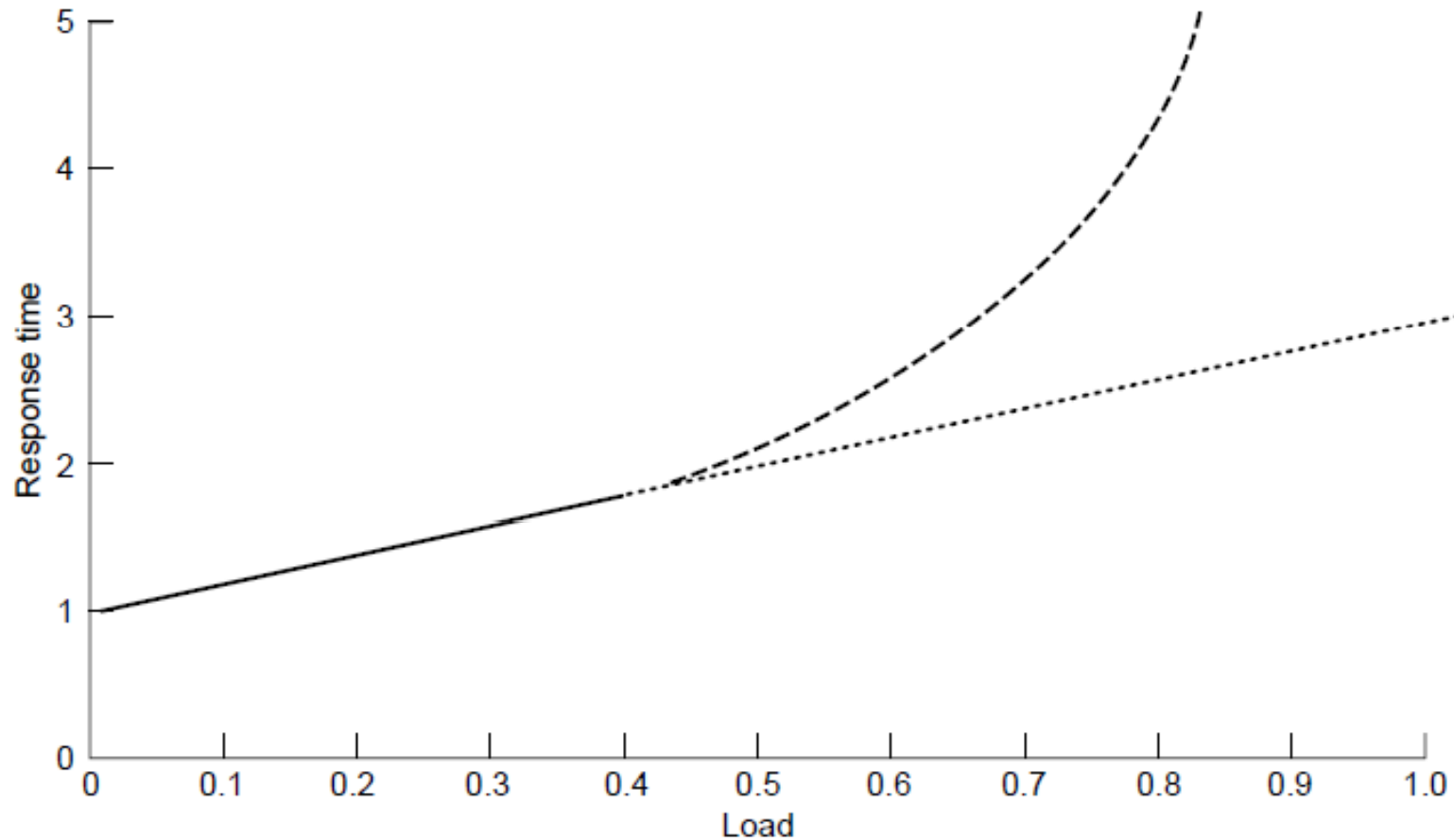

Response as a function of load.

System Design for Better Performance (1)

Rules of thumb

1. CPU speed more important than network speed
2. Reduce packet count to reduce software overhead
3. Minimize data touching
4. Minimize context switches
5. Minimize copying
6. You can buy more bandwidth but not lower delay
7. Avoiding congestion is better than recovering from it
8. Avoid timeouts

System Design for Better Performance (2)

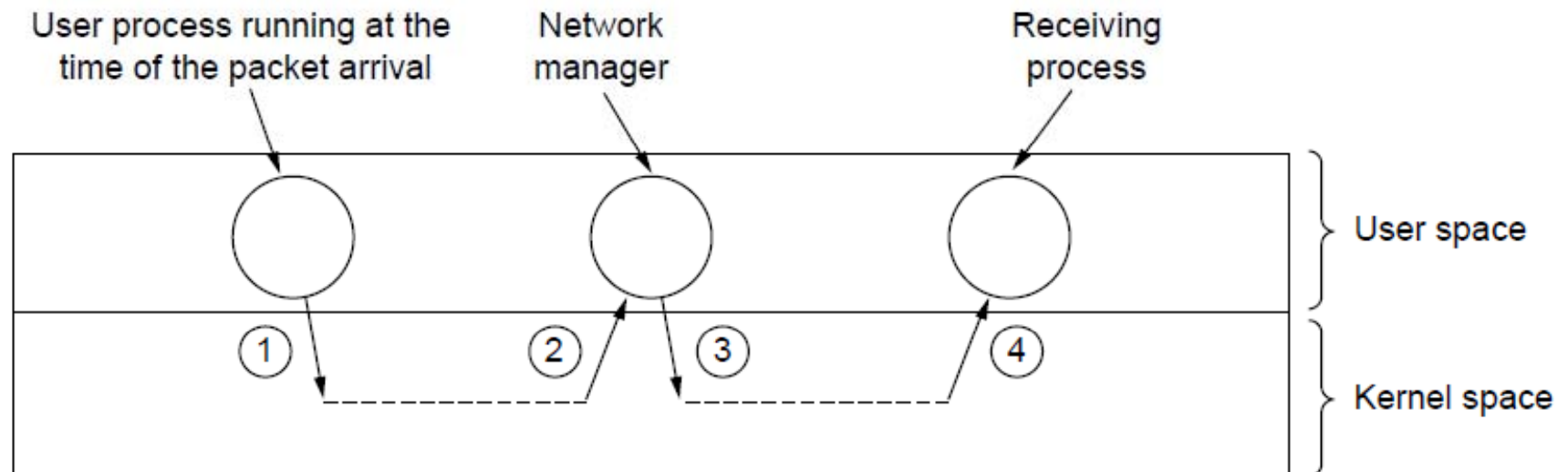

Four context switches to handle one packet with a user-space network manager.

Fast TPDU Processing (1)

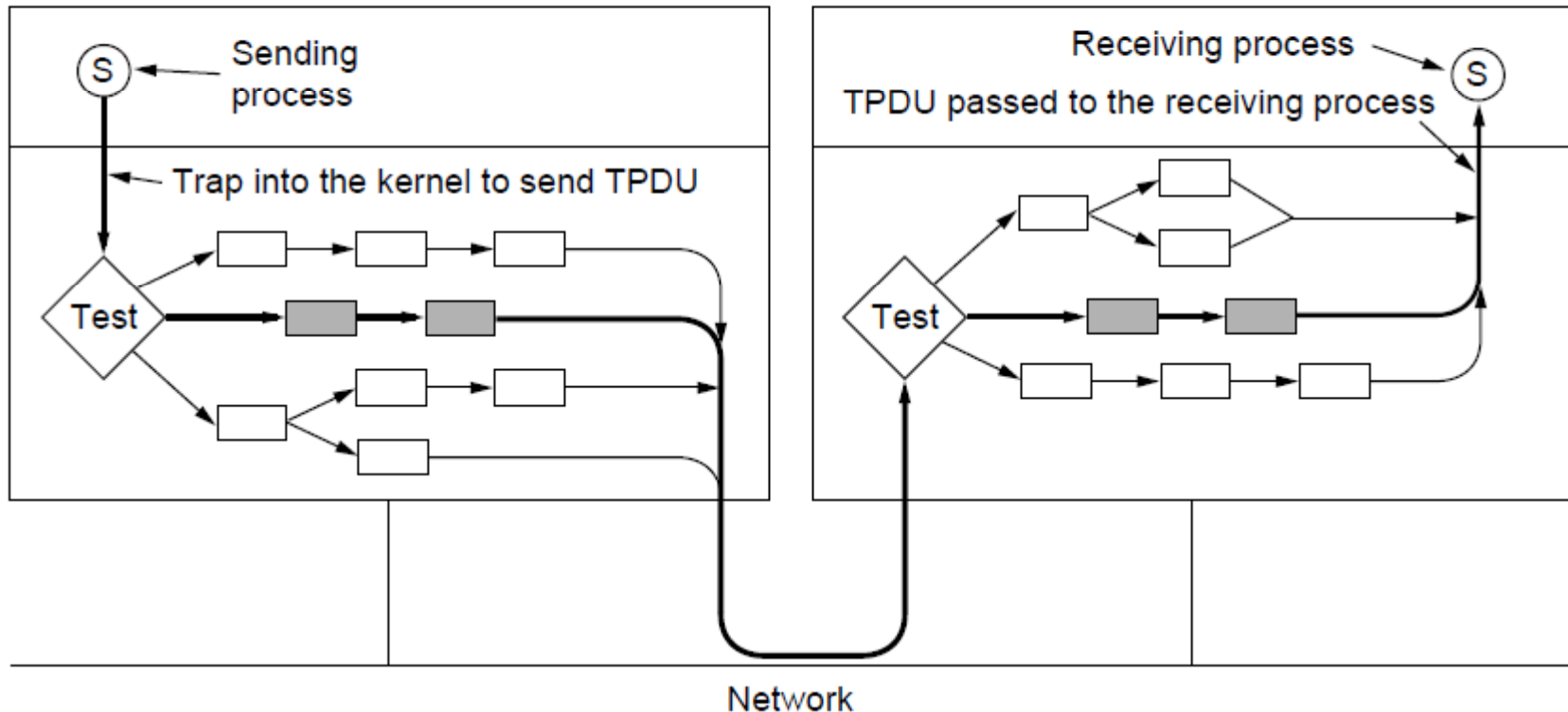

The fast path from sender to receiver is shown with a heavy line. The processing steps on this path are shaded.

Fast TPDU Processing (2)

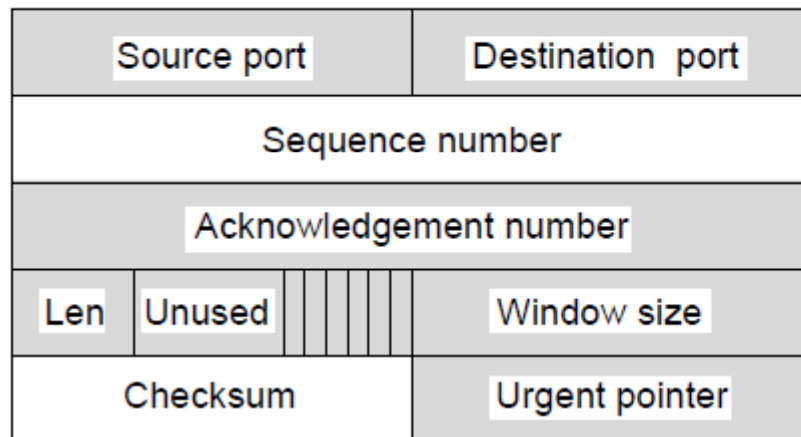

(a)

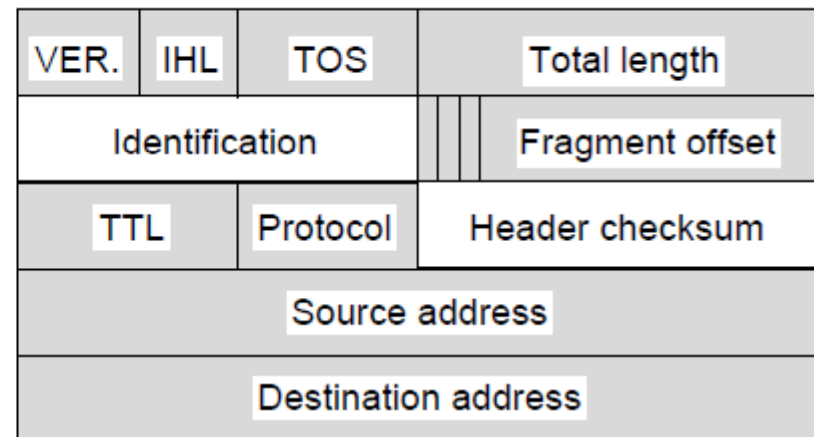

(b)

(a) TCP header. (b) IP header. In both cases, the shaded fields are taken from the prototype without change.

Protocols for High-Speed Networks (1)

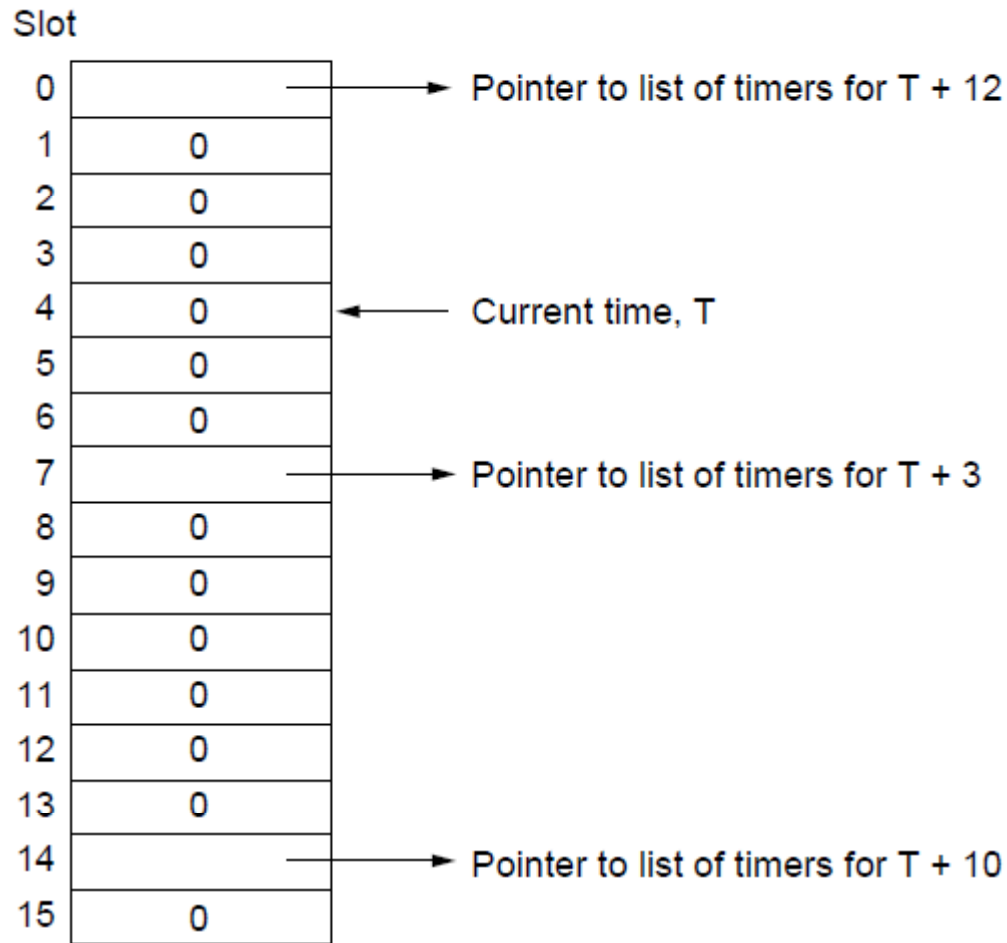

A timing wheel

Protocols for High-Speed Networks (2)

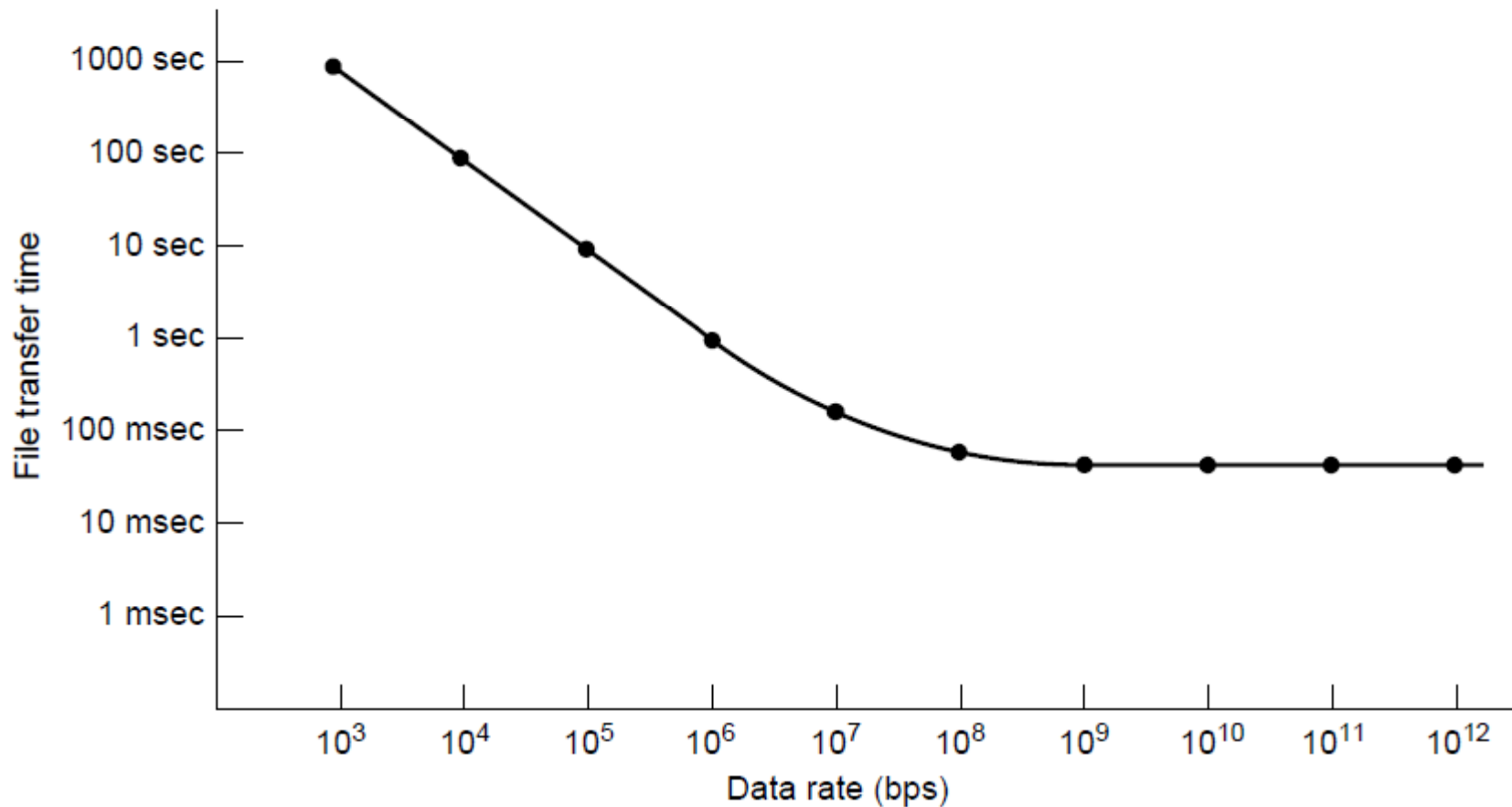

Time to transfer and acknowledge a
1-megabit file over a 4000-km line

Delay Tolerant Networking

- DTN Architecture
- The Bundle Protocol

DTN Architecture (1)

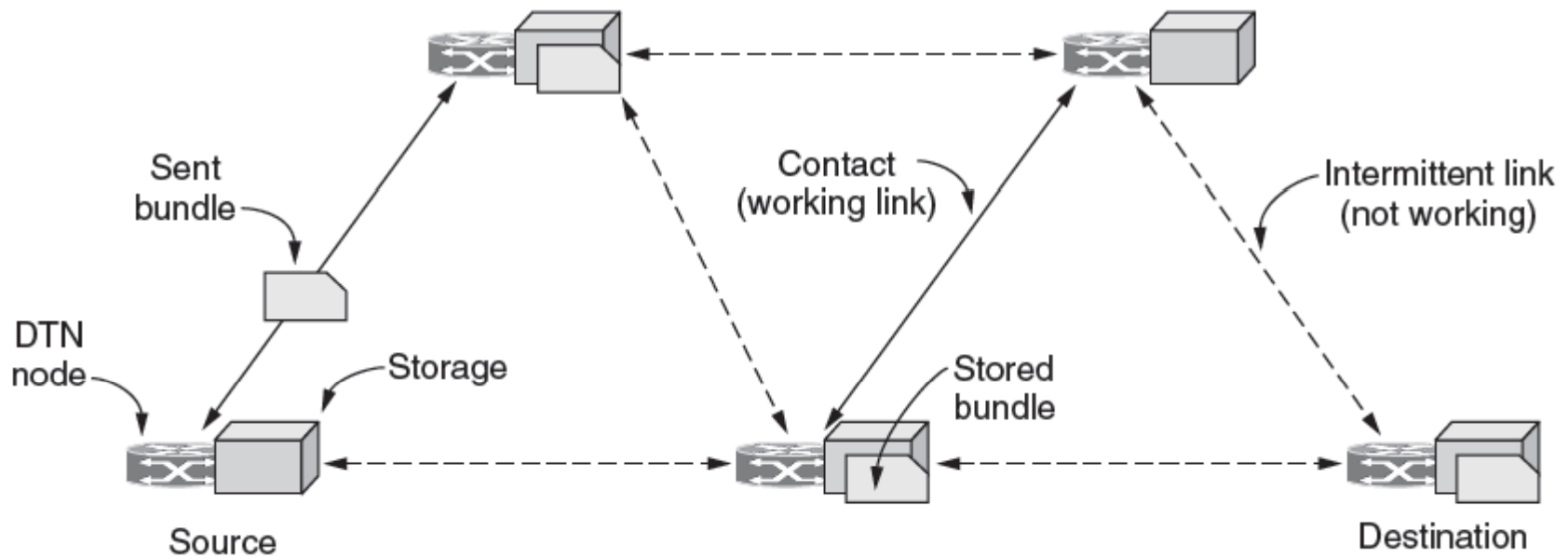

Delay-tolerant networking architecture

DTN Architecture (2)

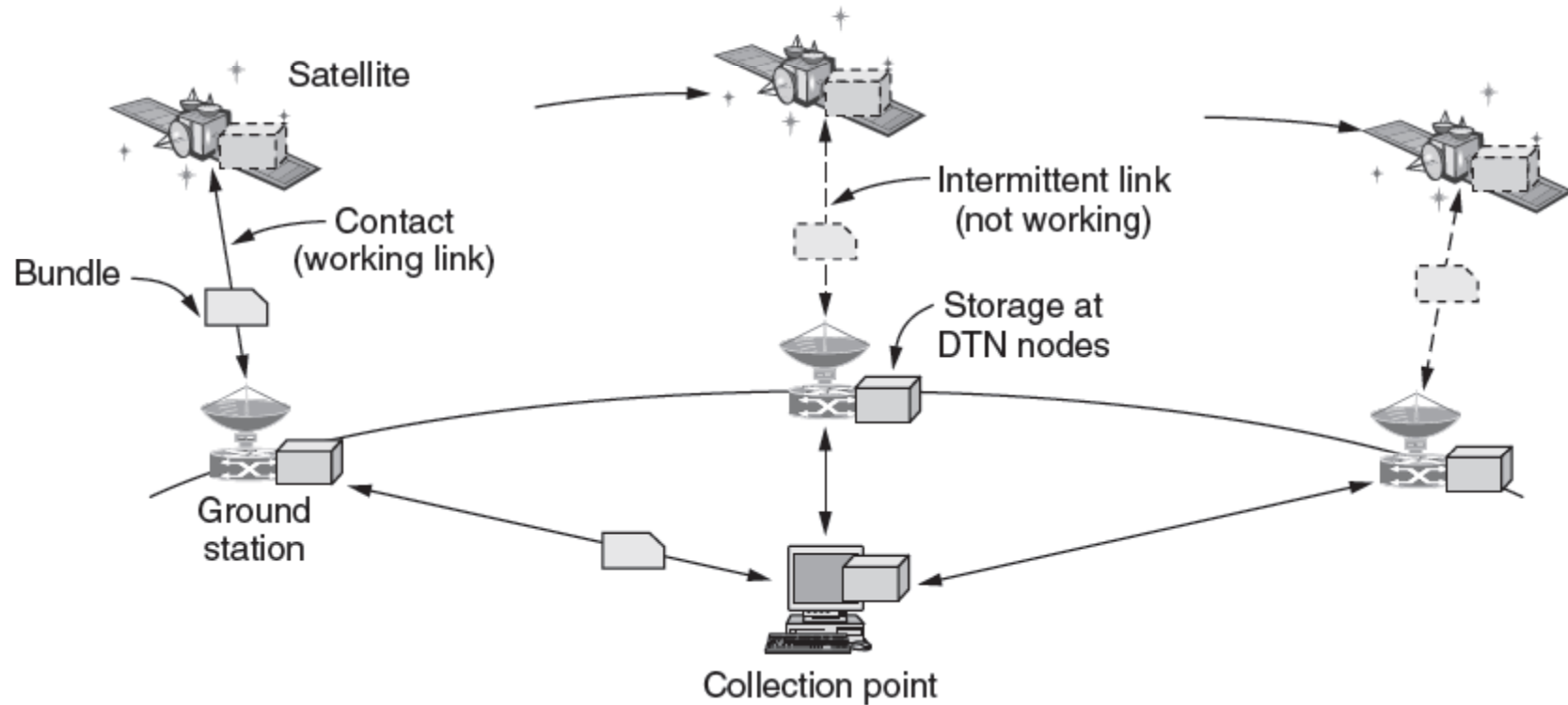

Use of a DTN in space.

The Bundle Protocol (1)

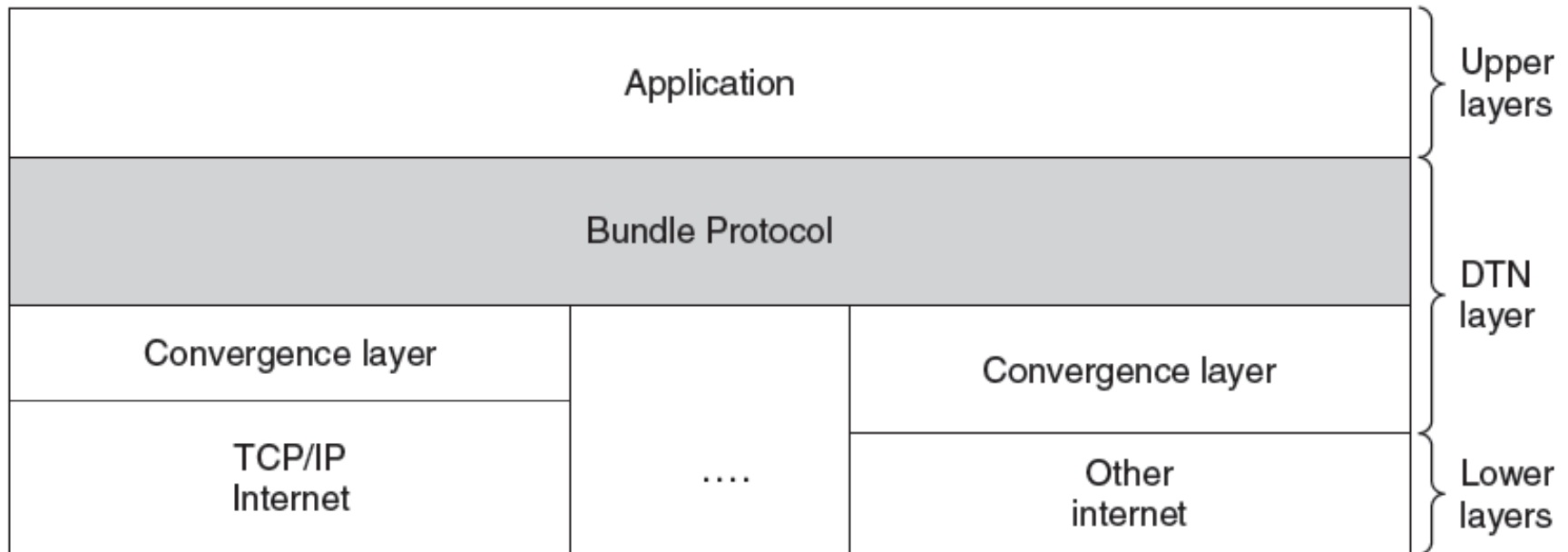

Delay-tolerant networking protocol stack.

The Bundle Protocol (2)

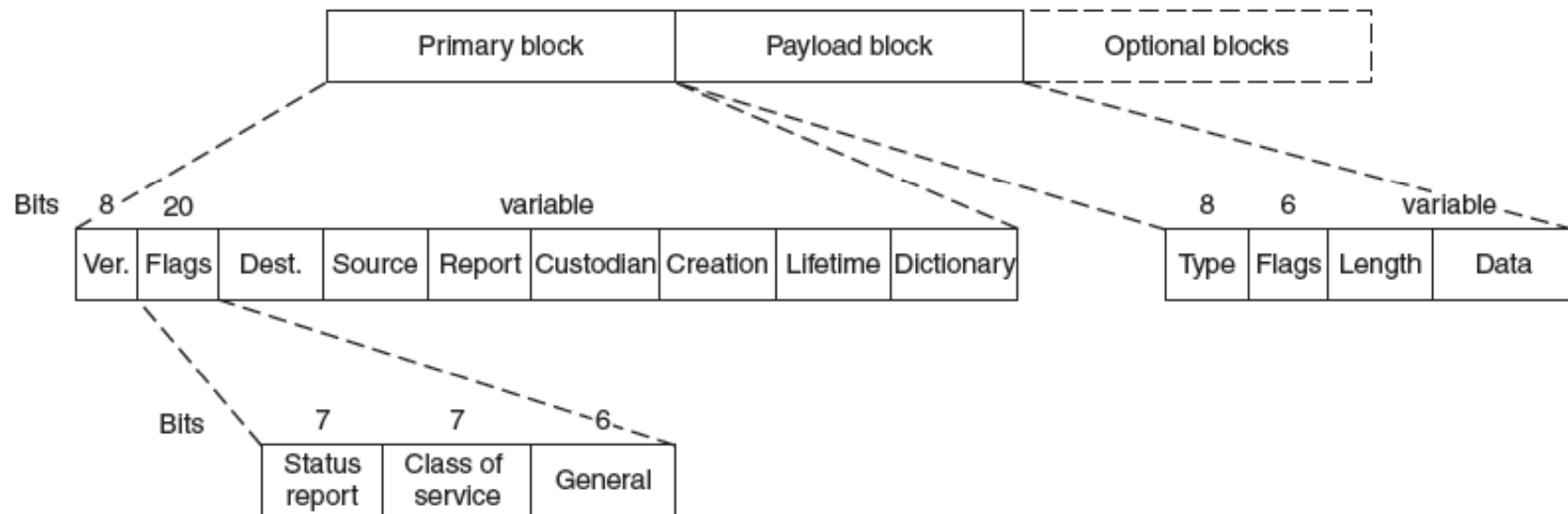

Bundle protocol message format.

End

Chapter 6